

sets

Inserts

Face milling cutters

Square shoulder cutters

Slot cutters







Porcupine cutters

Specific applications and sets

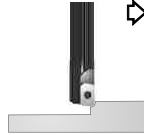

Specific applications and Sets

Specific applications

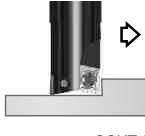
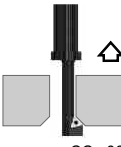
02₁4.00 Spot facing milling cutters  Page F.02 CC.. 0602.. CC.. 09T3..	0624.21 Chamfering cutters  Page F.04 TC.. 1102..	0724.21 Chamfering cutters  Page F.04 TC.. 1102..	1220.21 Face and square 90°  Page F.06 AP.. 1003..	2220.21 Face and square 90°  Page F.06 AP.. 1003..	1135.01 Convexe milling cutters  Page F.08 ADMW-C 1503..
1235.01 Concave milling cutters  Page F.10 ADMW-R 1503..	1235.07 Concave milling cutters  Page F.10 ADMW-R 1503..	16₃4.2₁ Chamfering cutters  Page F.12 TC.. 1102.. TC.. 1603..	1725.₂7 Chamfering cutters  Page F.14 ADMW-R 1503..	1735.₀7 Chamfering cutters  Page F.15 ADMW-C 1503..	1744.₀7 Chamfering cutters  Page F.16 SC.. 1204..
3314.0⁰ Multi-function  Page F.18 CCKT 0602.. CCKT 1204..	9614.61 Back draft spot facing  Page F.20 CC.. 0602.. CC.. 09T3..	9624.61 Back draft countersink  Page F.21 CC.. 0602.. TC.. 1102..			

Sets

SET MAXICUT Spot facing milling cutters  Page F.03 CC.. 0602.. CC.. 09T3..	SET MINICUT Chamfering cutters  Page F.05 TC.. 1102..	SET 1220 Face and square 90°  Page F.07 AP.. 1003..	SET 1135 Convexe milling cutters  Page F.09 ADMW-C 1503..	SET 1235 Concave milling cutters  Page F.11 ADMW-R 1503..	SET MULTICUT Chamfering cutters  Page F.13 TC.. 1102.. TC.. 16T3..
SET CCKT Multi-function  Page F.19 CCKT 0602.. CCKT 1204..					

Specific applications
and sets

Profile milling

Solid carbide

Drills

Boring heads

Arbors and
adaptors

Specific applications and sets

For more information see page:

Contents: F.02
Sets: F.03
Tools: F.10

Inserts

Face milling cutters

Square shoulder cutters

Slot cutters

Porcupine cutters

Specific applications and sets



Characteristics:

Spot facing milling cutters for flat screw heads.

The inserts are fixed by Torx screw that allow a good chip evacuation and easy use.

Applications:

Flat countersink.

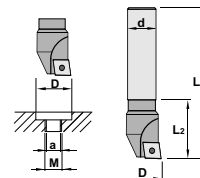
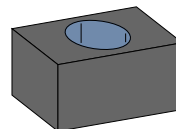
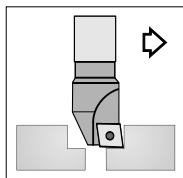

02¹₃4.00

Ref.		D	d	a	L	L ₂	M	Insert size	
0214.00.011	1	11	12	4	85	15	M6	CC.. 0602..	0,100
0214.00.014	1	14	12	5	85	19	M8	CC.. 0602..	0,100
0234.00.017	1	17	16	5	95	30	M10	CC.. 09T3..	0,125
0234.00.019	1	19	16	5	95	32	M12	CC.. 09T3..	0,125
0234.00.022	1	22	16	6	95	32	M14	CC.. 09T3..	0,150
0234.00.025	1	25	16	8	95	32	M16	CC.. 09T3..	0,150

Ref.		
0214.00.011	1425	5507
0214.00.014	1425	5507
0234.00.017	1440	5515
0234.00.019	1440	5515
0234.00.022	1440	5515
0234.00.025	1440	5515

 	CC..			Positive 7° clearance - 80° rhombic inserts.
	l	s	d	
Ref.	CC.. 0602..	6,45	2,38	6,35
	CC.. 09T3..	9,65	3,97	9,52
	CCGT-AL	CCKT	CCMW	

For more information see page: A.12



Characteristics:

Spot facing milling cutters for flat screw heads.

The inserts are fixed by Torx screw that allow a good chip evacuation and easy use.

Applications:

Flat countersink.

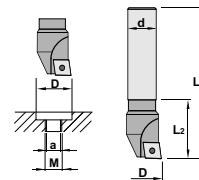
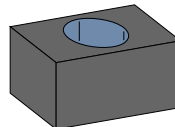
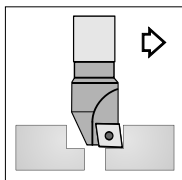

SET MAXICUT

Ref.			D	d	a	L	L2	M	Insert size	
0214.00.011	1		11	12	4	85	15	M6	CC.. 0602..	0,800
0214.00.014	1		14	12	5	85	19	M8	CC.. 0602..	
0234.00.017	1		17	16	5	95	30	M10	CC.. 09T3..	
0234.00.019	1		19	16	5	95	32	M12	CC.. 09T3..	
0234.00.022	1		22	16	6	95	32	M14	CC.. 09T3..	
0234.00.025	1		25	16	8	95	32	M16	CC.. 09T3..	

Ref.		
0214.00.011	1425	5507
0214.00.014	1425	5507
0234.00.017	1440	5515
0234.00.019	1440	5515
0234.00.022	1440	5515
0234.00.025	1440	5515

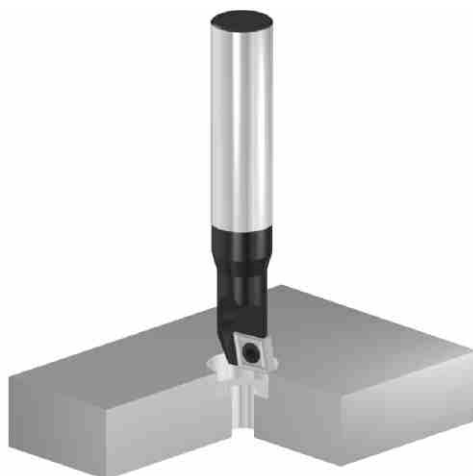

	CC..				Positive 7° clearance - 80° rhombic inserts.
	Ref.	l	s	d	
	CC.. 0602..	6,45	2,38	6,35	For more information see page: A.12
	CC.. 09T3..	9,65	3,97	9,52	
	CCGT-AL	CCKT	CCMW		

Specific applications and sets

Profile milling

Solid carbide

Drills

Boring heads

Arbors and adaptors

Inserts

Face milling cutters

Square shoulder cutters

Slot cutters

Porcupine cutters

Specific applications and sets



Characteristics:

Countersink milling cutter for specific operations. The insert is fixed by Torx screw that allow a good chip evacuation and an easy use.

Applications:

This chamfering milling cutters work well on steels, alloyed steels, stainless steels and refractors. This general milling cutter for diversified manufacture is recommended for small conventional milling machines and machining centers

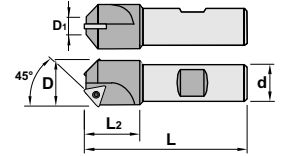
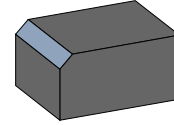
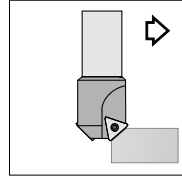

0624.21

Ref.		D1	D	L	L2	d	Insert size	
0624.21.016	1	1,2	16	70	24	12	TC.. 1102..	0,100
0624.21.021	2	8,5	21	90	30	20	TC.. 1102..	0,150



Ref.	0624.21.016	1425	5507
	0624.21.021	1425	5507

Characteristics:

Countersink milling cutter for specific operations. The insert is fixed by Torx screw that allow a good chip evacuation and an easy use.

Applications:

This chamfering milling cutters work well on steels, alloyed steels, stainless steels and refractors. This general milling cutter for diversified manufacture is recommended for small conventional milling machines and machining centers

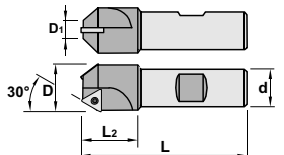
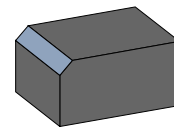
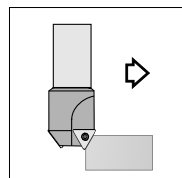

0724.21

Ref.		D1	D	L	L2	d	Insert size	
0724.21.016	1	5,4	16	70	24	12	TC.. 1102..	0,100
0724.21.026	2	15,8	26	90	30	20	TC.. 1102..	0,170



Ref.	0724.21.016	1425	5507
	0724.21.026	1425	5507

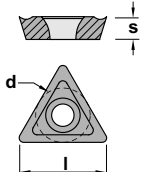

TC..

l

s

d

Positive 7° clearance - Triangular inserts.

Ref.	TC.. 1102..	11,00	2,38	6,35
------	-------------	-------	------	------

For more information see page: A.20

TCGT-AL

TCMT-39

TCMW





Characteristics:

Countersink milling cutter for specific operations. The insert is fixed by Torx screw that allow a good chip evacuation and an easy use.

Applications:

This chamfering milling cutters work well on steels, alloyed steels, stainless steels and refractors. This general milling cutter for diversified manufacture is recommended for small conventional milling machines and machining centers

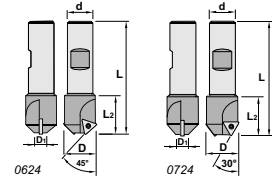
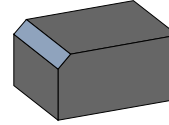
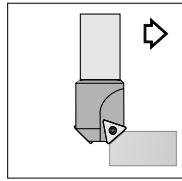

SET MINICUT			D1	D	L	L2	d	Insert size	
Ref.	0624.21.016	1	1,2	16	70	24	12	TC.. 1102..	0,600
	0624.21.021	2	8,5	21	90	30	20	TC.. 1102..	
	0724.21.016	1	5,4	16	70	24	12	TC.. 1102..	
	0724.21.026	2	15,8	26	90	30	20	TC.. 1102..	

Ref.		
0624.21.016	1425	5507
0624.21.021	1425	5507
0724.21.016	1425	5507
0724.21.026	1425	5507



	TC..				Positive 7° clearance - Triangular inserts. For more information see page: A.20	
	Ref.	TC.. 1102..	l	s		d
			11,00	2,38		6,35
	TCGT-AL	TCMT-39	TCMW			

Specific applications and sets

Profile milling

Solid carbide

Drills

Boring heads

Arbors and adaptors

Inserts

Face milling cutters

Square shoulder cutters

Slot cutters

Porcupine cutters

Specific applications and sets



Characteristics:

This positive milling cutter with an exact angle of 90° uses very strong inserts allowing deep passes and high feed per teeth. The insert is fixed by a Torx screw that allows a good chip evacuation and an easy use. Milling cutter equipped with short Weldon shank.

Applications:

This face and square (angle 90°), slot and side milling cutter works well on steels, alloyed steels, stainless steels, refractory casts and aluminium alloys. This general milling cutter for diversified manufacture is recommended for conventional milling machines and machining centers.

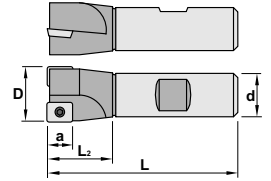
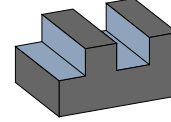
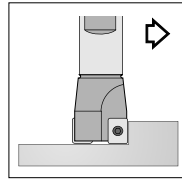

1220.21

Ref.		D	d	a	L2	L	Insert size	
1220.21.012	1	12	16	10	25	85	AP.. 1003..	0,100
1220.21.016	2	16	16	10	25	85	AP.. 1003..	0,150
1220.21.020	3	20	20	10	30	90	AP.. 1003..	0,150



Ref.	1200.21.012	1425	5507
	1220.21.016	1425	5507
	1220.21.020	1425	5507

Characteristics:

This super positive drill milling cutter with an exact angle of 90° uses strong inserts allowing deep passes. The insert is fixed by a Torx screw that allows a good chip evacuation and an easy use.

Milling cutter equipped with short Weldon shank.

Applications:

This drill milling cutter, works well on steels, alloyed steels, stainless steels, refractory casts and aluminium alloys. This general milling cutter for diversified manufacture is recommended for conventional milling machines and machining centers.

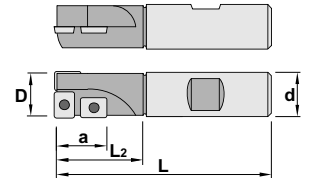
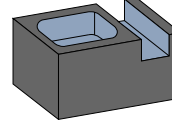
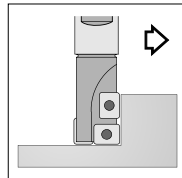

2220.21

Ref.		D	d	a	L2	L	Insert size	
2220.21.020	1+1	20	20	19	35	90	AP.. 1003..	0,150



Ref.	2220.21.020	1425	5507
------	-------------	------	------

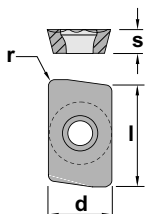

AP..

Ref.	AP.. 1003..	l	s	d
		9,52	3,18	6,35

Positive 11° clearance - Rectangular inserts.

For more information see page: A.11

APHT-AL

APKT





Characteristics:

This positive milling cutter with an exact angle of 90° uses very strong inserts allowing deep passes and high feed per teeth. The insert is fixed by a Torx screw that allows a good chip evacuation and an easy use. Milling cutter equipped with short Weldon shank.

Applications:

This face and square (angle 90°), slot and side milling cutter works well on steels, alloyed steels, stainless steels, refractory casts and aluminium alloys. This general milling cutter for diversified manufacture is recommended for conventional milling machines and machining centers.

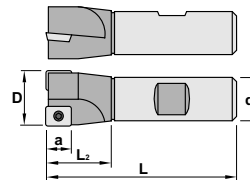
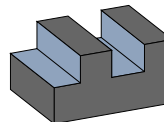
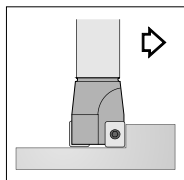

SET 1220			D	d	a	L2	L	Insert size	
Ref.	1220.21.012	1	12	16	10	25	85	AP.. 1003..	0,650
	1220.21.016	2	16	16	10	25	85	AP.. 1003..	
	1220.21.020	3	20	20	10	30	90	AP.. 1003..	
	2220.21.020	1+1	20	20	19	35	90	AP.. 1003..	

Ref.		
1220.21.012	1425	5507
1220.21.016	1425	5507
1220.21.020	1425	5507
2220.21.020	1425	5507

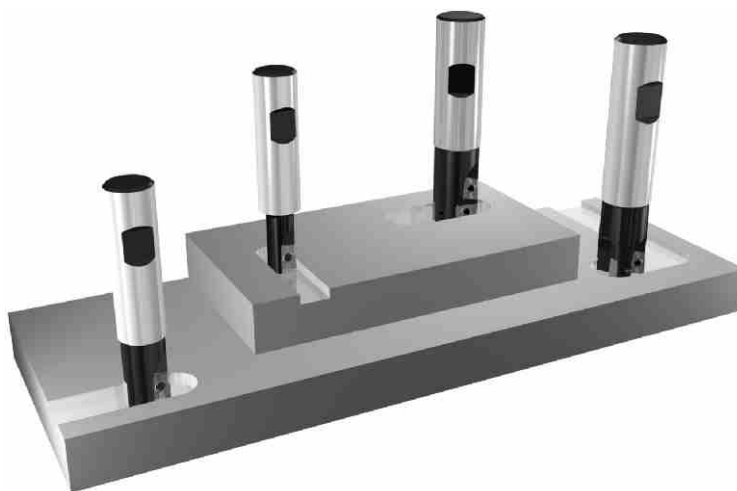

	AP..		l	s	d	Positive 11° clearance - Rectangular insert. For more information see page: A.11
	Ref.	AP.. 1003..	9,52	3,18	6,35	
	APHT-AL	APKT				

Specific applications and sets

Profile milling

Solid carbide

Drills

Boring heads

Arbors and adaptors

Inserts

Face milling cutters

Square shoulder cutters

Slot cutters

Porcupine cutters

Specific applications and sets



Characteristics:

Convex milling cutters for specific applications.

The inserts are fixed by Torx screw that allow a good chip evacuation and easy use.

Applications:

This chamfering milling cutters work well on steels, alloyed steels, stainless steels and refractors.

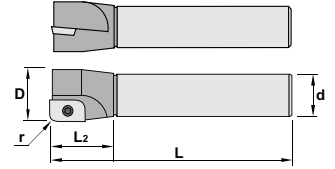
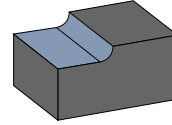
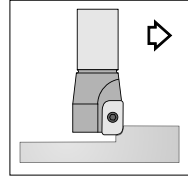

1135.01

Ref.		d	D	L	L2	r _{min}	r _{max}	Insert size	
1135.01.01610	1	16	16	120	35	1,0	3,0	ADMW-C 1503R1.0 / 3.0	0,200
1135.01.01635	1	16	16	120	35	3,5	6,0	ADMW-C 1503R3.5 / 6.0	0,200



Ref.	1135.01.01610	1135.01.01635	1440	1440	5515	5515

ADMW-C

Ref.	ADMW 1503R1.0-C	ADMW 1503R1.5-C	ADMW 1503R2.0-C	ADMW 1503R2.5-C	ADMW 1503R3.0-C	ADMW 1503R3.5-C	ADMW 1503R4.0-C	ADMW 1503R4.5-C	ADMW 1503R5.0-C	ADMW 1503R6.0-C
r	1,00	1,50	2,00	2,50	3,00	3,50	4,00	4,50	5,00	6,00
s	3,18	3,18	3,18	3,18	3,18	3,18	3,18	3,18	3,18	3,18
d	9,52	9,52	9,52	9,52	9,52	9,52	9,52	9,52	9,52	9,52

Positive 11° clearance - Rectangular inserts.

For more information see page: A.10

R4.5-C	R5.0-C	R6.0-C				
R1.0-C	R1.5-C	R2.0-C	R2.5-C	R3.0-C	R3.5-C	R4.0-C

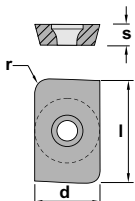



Characteristics:

Convex milling cutters for specific applications.

The inserts are fixed by Torx screw that allow a good chip evacuation and easy use.

Applications:

This chamfering milling cutters work well on steels, alloyed steels, stainless steels and refractors.

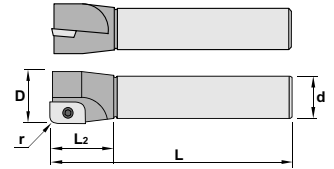
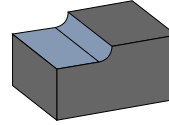
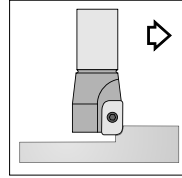

SET 1135			d	D	L	L2	r _{min}	r _{max}	Insert size	
Ref.	1135.01.01610	1	16	16	120	35	1,0	3,0	ADMW-C 1503R1.0 / 3.0	0,550
	1135.01.01635	1	16	16	120	35	3,5	6,0	ADMW-C 1503R3.5 / 6.0	

Ref.	1135.01.01610	1440	5515
	1135.01.01635	1440	5515



Ref.	ADMW-C				Positive 11° clearance - Rectangular inserts.		
	r	s	d				
	ADMW 1503R1.0-C	1,00	3,18	9,52			
	ADMW 1503R1.5-C	1,50	3,18	9,52			
	ADMW 1503R2.0-C	2,00	3,18	9,52			
	ADMW 1503R2.5-C	2,50	3,18	9,52			
	ADMW 1503R3.0-C	3,00	3,18	9,52			
	ADMW 1503R3.5-C	3,50	3,18	9,52			
	ADMW 1503R4.0-C	4,00	3,18	9,52			
	ADMW 1503R4.5-C	4,50	3,18	9,52			
	ADMW 1503R5.0-C	5,00	3,18	9,52			
	ADMW 1503R6.0-C	6,00	3,18	9,52			
	R1.0-C	R1.5-C	R2.0-C	R2.5-C	R3.0-C	R3.5-C	R4.0-C

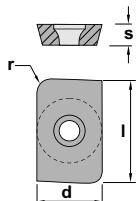

For more information see page: A.10

Specific applications and sets

Profile milling

Solid carbide

Drills

Boring heads

Arbors and adaptors

Inserts

Face milling cutters

Square shoulder cutters

Slot cutters

Porcupine cutters

Specific applications and sets



Characteristics:

Concave milling cutters for specific applications.

The inserts are fixed by Torx screw that allow a good chip evacuation and easy use.

Applications:

This chamfering milling cutters work well on steels, alloyed steels, stainless steels and refractors.

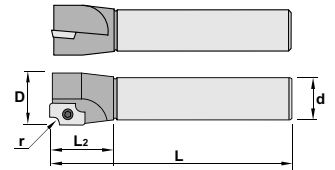
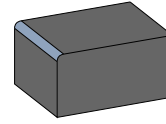
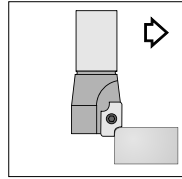

1235.01

Ref.	✳	d	D	L	L2	rmin	rmax	Insert size	kg
1235.01.01701	1	16	17	120	30	1,0	2,5	ADMW 1503R1.0 / 2.5	0,200
1235.01.01703	1	16	17	120	30	3,0	5,0	ADMW 1503R3.0 / 5.0	0,200



Ref.	1235.01.01701	1440	5515
	1235.01.01703	1440	5515

Characteristics:

Concave milling cutters for specific applications.

The inserts are fixed by Torx screw that allow a good chip evacuation and easy use.

Applications:

This chamfering milling cutters work well on steels, alloyed steels, stainless steels and refractors.

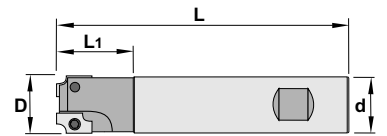
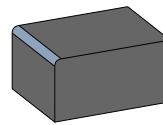
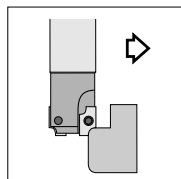

1235.07

Ref.	✳	D	d	L	L1	rmin	rmax	Insert size	kg
1235.07.02201	2	22	20	120	35	1,0	2,5	ADMW 1503R1.0 / 2.5	0,320
1235.07.02203	2	22	20	120	35	3,0	5,0	ADMW 1503R3.0 / 5.0	0,530



Ref.	1235.07.02201	1440	5515
	1235.07.02203	1440	5515

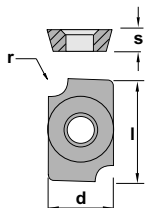

ADMW-R

Ref.	r	s	d
ADMW 1503R1.0	1.0	3,18	9,52
ADMW 1503R1.5	1.5	3,18	9,52
ADMW 1503R2.0	2.0	3,18	9,52
ADMW 1503R2.5	2.5	3,18	9,52
ADMW 1503R3.0	3.0	3,18	9,52
ADMW 1503R3.5	3.5	3,18	9,52
ADMW 1503R4.0	4.0	3,18	9,52
ADMW 1503R4.5	4.5	3,18	9,52
ADMW 1503R5.0	5.0	3,18	9,52

Positive 11° clearance - Rectangular inserts

For more information see page: A.10

R1.0-R	R1.5-R	R2.0-R	R2.5-R	R3.0-R	R3.5-R	R4.0-R



Characteristics:

Concave milling cutters for specific applications.

The inserts are fixed by Torx screw that allow a good chip evacuation and easy use.

Applications:

This chamfering milling cutters work well on steels, alloyed steels, stainless steels and refractors.

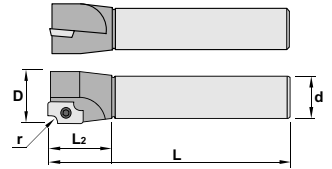
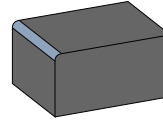
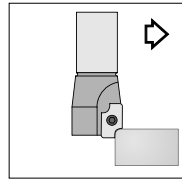

SET 1235			d	D	L	L2	r _{min}	r _{max}	Insert size	
Ref.	1235.01.01701	1	16	17	120	30	1,0	2,5	ADMW 1503R1.0 / 2.5	0,550
	1235.01.01703	1	16	17	120	30	3,0	5,0	ADMW 1503R3.0 / 5.0	

Ref.	1235.01.01701			1440						5515
	1235.01.01703			1440						5515



Ref.	ADMW-R				Positive 11° clearance - Rectangular inserts							
	r	s	d									
	ADMW 1503R1.0	1.0	3,18	9,52								
	ADMW 1503R1.5	1.5	3,18	9,52								
	ADMW 1503R2.0	2.0	3,18	9,52								
	ADMW 1503R2.5	2.5	3,18	9,52								
	ADMW 1503R3.0	3.0	3,18	9,52								
	ADMW 1503R3.5	3.5	3,18	9,52								
	ADMW 1503R4.0	4.0	3,18	9,52								
	ADMW 1503R4.5	4.5	3,18	9,52								
	ADMW 1503R5.0	5.0	3,18	9,52								

For more information see page: A.10	
R4.5-R	R5.0-R

R1.0-R	R1.5-R	R2.0-R	R2.5-R	R3.0-R	R3.5-R	R4.0-R

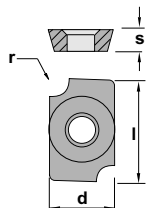

Specific applications and sets

Profile milling

Solid carbide

Drills

Boring heads

Arbors and adaptors

Inserts

Face milling cutters

Square shoulder cutters

Slot cutters

Porcupine cutters

Specific applications and sets



Characteristics:

Regulable chamfering milling cutter for specific operations. The insert is fixed by Torx screw that allow a good chip evacuation and an easy use.

Applications:

This chamfering milling cutter for diversified manufacture is recommended for small conventional milling machines and machining centers.

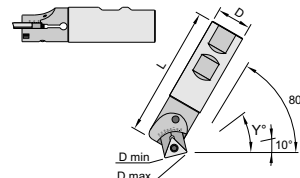
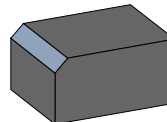
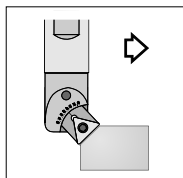

16²₃4.2¹₇

Ref.			D	L	Y	Dmin	Dmax	Insert size	
1624.21.020		1	20	100	10° - 80°	5	20	TC.. 1102..	0,250
1634.21.025		1	25	100	10° - 80°	5	23	TC.. 16T3..	0,250
1634.27.025		1	25	175	10° - 80°	5	23	TC.. 16T3..	0,500

Ref.				
1624.21.020	6921	1225	1095	5507
1634.21.025	6926	1240	1296	5515
1634.27.025	6926	1240	1296	5515

 	TC..				Positive 7° clearance - Triangular inserts.
	Ref.	l	s	d	
	TC.. 1102..	11,00	2,38	6,35	For more information see page: A.20
	TC.. 16T3..	16,50	3,97	9,52	
	TCGT-AL	TCMT-39	TCMW		



Characteristics:

Regulable chamfering milling cutter for specific operations.

The insert is fixed by Torx screw that allow a good chip evacuation and an easy use.

Applications:

This chamfering milling cutter for diversified manufacture is recommended for small conventional milling machines and machining centers.

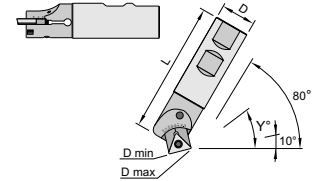
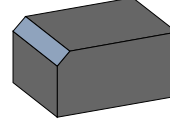
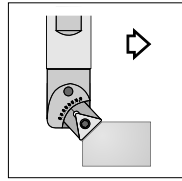

SET MULTICUT			D	L	Y	Dmin	Dmax	Insert size	
Ref.	1624.21.020	1	20	100	10°	5	26	TC.. 1102..	0,600
					20°	8	27		
					30°	10	27		
					40°	13	27		
					45°	14	27		
					50°	15	27		
					60°	17	26		
					70°	19	25		
					80°	20	24		
1634.21.025	1	25	100	10°	5	32	TC.. 16T3..	0,600	
				20°	6	33			
				30°	7	34			
				40°	10	33			
				45°	11	33			
				50°	13	32			
				60°	16	31			
				70°	19	29			
				80°	23	27			

Ref.				
1624.21.020	6921	1225	1095	5507
1634.21.025	6926	1240	1296	5515

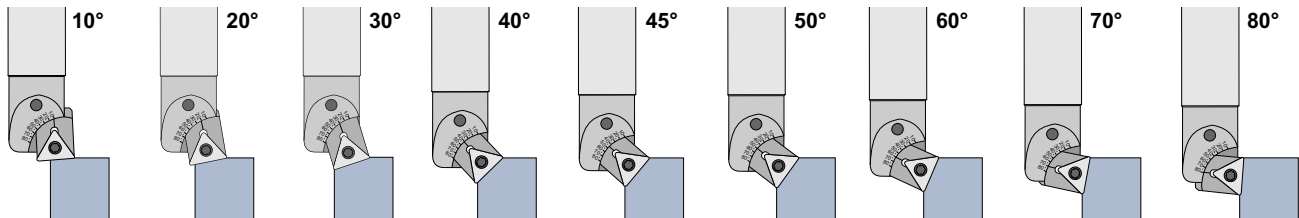

	TC..				Positive 7° clearance - Triangular inserts. For more information see page: A.20
	Ref.	l	s	d	
	TC.. 1102..	11,00	2,38	6,35	
TC.. 16T3..	16,50	3,97	9,52		
	TCGT-AL	TCMT-39	TCMW		

Specific applications and sets

Profile milling

Solid carbide

Drills

Boring heads

Arbors and adaptors

Inserts

Face milling cutters

Square shoulder cutters

Slot cutters

Porcupine cutters

Specific applications and sets



Characteristics:

Regulable concave milling cutters for specific applications.

The inserts are fixed by Torx screw that allow a good chip evacuation and easy use.

Applications:

This chamfering milling cutters work well on steels, alloyed steels, stainless steels and refractors.

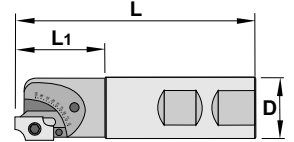
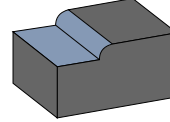
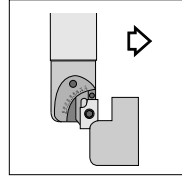

1725.0⁷₂

Ref.	✳	D	L	L1	Dmin	Dmax	Insert size	kg
1725.07.025	1	25,5	104	37	26,5	33,0	ADMW-R 1503	0,250
1725.27.025	1	25,5	178	37	26,5	33,0	ADMW-R 1503	0,500



Ref.	1725.07.025	6925	1240	1296	5515
	1725.27.025	6925	1240	1296	5515

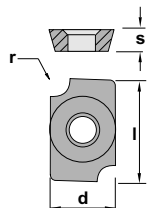
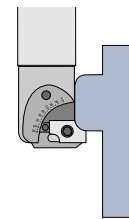
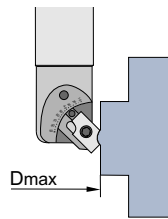
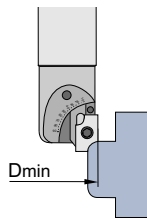

ADMW-R

Ref.	r	s	d
ADMW 1503R1.0	1.0	3,18	9,52
ADMW 1503R1.5	1.5	3,18	9,52
ADMW 1503R2.0	2.0	3,18	9,52
ADMW 1503R2.5	2.5	3,18	9,52
ADMW 1503R3.0	3.0	3,18	9,52
ADMW 1503R3.5	3.5	3,18	9,52
ADMW 1503R4.0	4.0	3,18	9,52
ADMW 1503R4.5	4.5	3,18	9,52
ADMW 1503R5.0	5.0	3,18	9,52

Positive 11° clearance - Rectangular inserts.

For more information see page: A.10

R1.0	R1.5	R2.0	R2.5	R3.0	R3.5	R4.0	R4.5	R5.0



Characteristics:

Regulable convex milling cutters for specific applications.

The inserts are fixed by Torx screw that allow a good chip evacuation and easy use.

Applications:

This chamfering milling cutters work well on steels, alloyed steels, stainless steels and refractors.

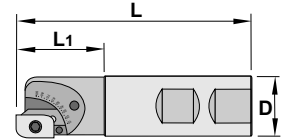
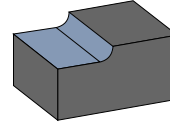
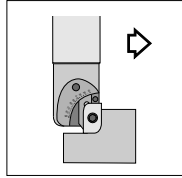

1735.07			D	L	L1	Dmin	Dmax	Insert size	
Ref.	1735.07.025	1	25,5	104	37	26,5	34,0	ADMW-C 1503	0,360
	1735.27.025	1	25,5	178	37	26,5	34,0	ADMW-C 1503	0,650

Ref.				
1735.07.025	6935	1240	1296	5515
1735.27.025	6935	1240	1296	5515

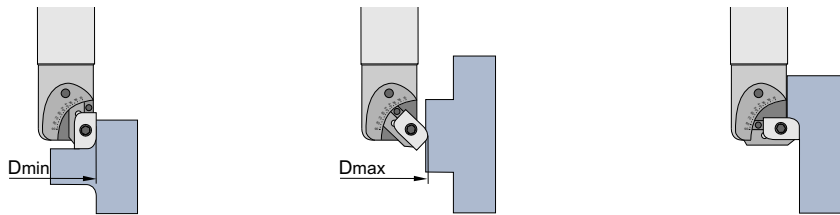

Ref.	ADMW-C			Positive 15° clearance - Rectangular inserts.		
	r	s	d	R4.5-C	R5.0-C	R6.0-C
ADMW 1503R1.0-C	1,00	3,18	9,52			
ADMW 1503R1.5-C	1,50	3,18	9,52			
ADMW 1503R2.0-C	2,00	3,18	9,52			
ADMW 1503R2.5-C	2,50	3,18	9,52			
ADMW 1503R3.0-C	3,00	3,18	9,52			
ADMW 1503R3.5-C	3,50	3,18	9,52			
ADMW 1503R4.0-C	4,00	3,18	9,52			
ADMW 1503R4.5-C	4,50	3,18	9,52			
ADMW 1503R5.0-C	5,00	3,18	9,52			
ADMW 1503R6.0-C	6,00	3,18	9,52			

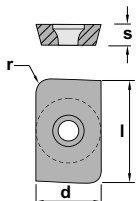

For more information see page: A.10

Specific applications and sets

Profile milling

Solid carbide

Drills

Boring heads

Arbors and adaptors

Specific applications and sets

For more information see page:

Contents: F.02
Sets: F.03
Tools: F.10

Inserts

Face milling cutters

Square shoulder cutters

Slot cutters

Porcupine cutters

Specific applications and sets



Characteristics:

Regulable chamfering milling cutter for specific operations.

The insert is fixed by Torx screw that allow a good chip evacuation and an easy use.

Applications:

This chamfering milling cutter for diversified manufacture is recommended for small conventional milling machines and machining centers.

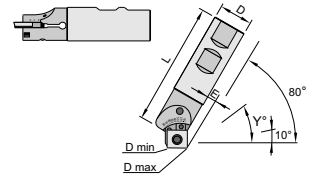
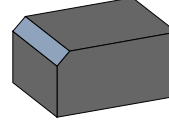
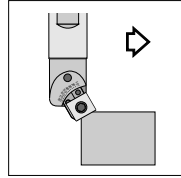

1744.⁰/₂7

Ref.		D	L	Y	Dmin	Dmax	Insert size	
1744.07.025	1	29	101	10°	7,5	30,0	SC.. 1204..	0,250
1744.27.025	1	29	176	20°	10,0	32,0	SC.. 1204..	0,500
				30°	13,0	32,5		
				40°	16,5	33,5		
				45°	17,5	33,5		
				50°	19,0	33,5		
				60°	22,0	33,5		
				70°	24,5	32,5		
				80°	27,0	31,0		

Ref.					
1744.07.025	6944	1244	1296	5520	
1744.27.025	6944	1244	1296	5520	

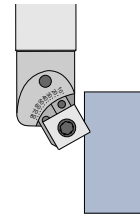
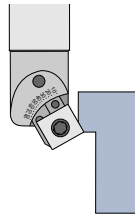
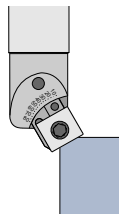

	SC..				Positive 7° clearance - Square inserts.
	Ref.	l	s	d	
	SC.. 1204..	12,70	4,76	12,70	
	SCGT-AL	SCMT-39	SCMW		

For more information see page: A.16



Specific applications
and sets

Profile milling

Solid carbide

Drills

Boring heads

Arbors and
adaptors

Inserts

Face milling cutters

Square shoulder cutters

Slot cutters

Porcupine cutters

Specific applications and sets



Characteristics: Multi-function centre-cutting end mills.

Applications: Multiple applications - Side milling, drilling and face milling.

Less time in tool changing on both-conventional and N/C machines.

Easily able to machine in roughing and finishing applications because of the high rake geometry and high helix which reduce cutting forces for a smoother cut.

Longer tool life may be expected because of the low cutting forces generated.

Improved performance will be seen in comparison to conventional end mills and mill-drills, especially when ramp milling, drilling, contouring, helical interpolation of bores, pockets or normal profiling.

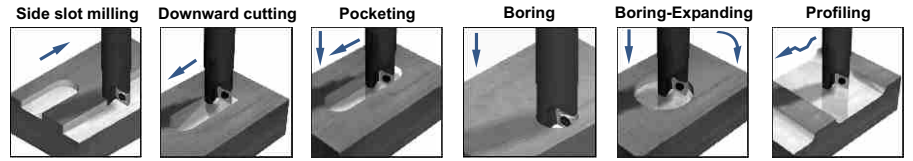
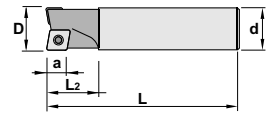

3314.0⁰₁

Ref.		D	d	L	L2	a	Insert size	
3314.00.012	1	12	16	100	25	5,0	CCKT 060204	0,120
3314.00.016	2	16	16	100	25	5,0	CCKT 060204 / 080308	0,160
3314.00.020	2	20	20	125	32	7,0	CCKT 080308 / 09T308	0,300
3314.00.025	2	25	25	125	40	7,6	CCKT 09T308 / 120408	0,480
3314.01.012	1	12	16	150	25	5,0	CCKT 060204	0,210
3314.01.016	2	16	16	175	25	5,0	CCKT 060204 / 080308	0,250
3314.01.020	2	20	20	175	32	7,0	CCKT 080308 / 09T308	0,400
3314.01.025	2	25	25	200	40	7,6	CCKT 09T308 / 120408	0,700

Ref.				
3314.00.012	1425	-	5507	-
3314.00.016	1425	1430	5507	5508
3314.00.020	1430	1440	5508	5515
3314.00.025	1440	1245	5515	-
3314.01.012	1425	-	5507	-
3314.01.016	1425	1430	5507	5508
3314.01.020	1430	1440	5508	5515
3314.01.025	1440	1245	5515	-

CCKT		l	s	d	Positive 7° clearance - 80° rhombic inserts.
Ref.	CCKT 0602..	6,45	2,38	6,35	
	CCKT 0803..	8,05	3,18	7,94	
	CCKT 09T3..	9,65	4,00	9,52	
	CCKT 1204..	12,90	4,76	12,70	
For more information see page: A.12					
	CCKT				



Characteristics: Multi-function centre-cutting end mills.

Applications: Multiple applications - Side milling, drilling and face milling.

Less time in tool changing on both-conventional and N/C machines.

Easily able to machine in roughing and finishing applications because of the high rake geometry and high helix which reduce cutting forces for a smoother cut.

Longer tool life may be expected because of the low cutting forces generated.

Improved performance will be seen in comparison to conventional end mills and mill-drills, especially when ramp milling, drilling, contouring, helical interpolation

of bores, pockets or normal profiling.

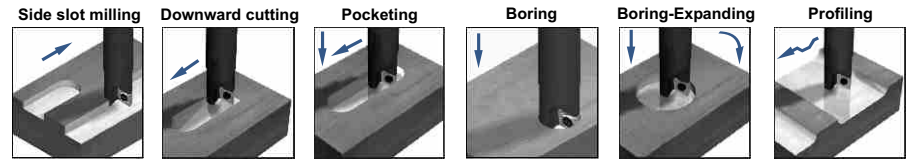
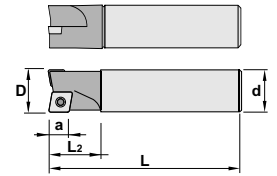

CCKT			D	d	L	L2	a	Insert size	
Ref.	3314.00.012	1	12	16	100	25	5,0	CCKT 060204	1,350
	3314.00.016	2	16	16	100	25	5,0	CCKT 060204 / 080308	
	3314.00.020	2	20	20	125	32	7,0	CCKT 080308 / 09T308	
	3314.00.025	2	25	25	125	40	7,6	CCKT 09T308 / 120408	
	3314.01.012	1	12	16	150	25	5,0	CCKT 060204	
	3314.01.016	2	16	16	175	25	5,0	CCKT 060204 / 080308	
	3314.01.020	2	20	20	175	32	7,0	CCKT 080308 / 09T308	
	3314.01.025	2	25	25	200	40	7,6	CCKT 09T308 / 120408	

Ref.				
3314.00.012	1425	-	5507	-
3314.00.016	1425	1430	5507	5508
3314.00.020	1430	1440	5508	5515
3314.00.025	1440	1245	5515	-
3314.01.012	1425	-	5507	-
3314.01.016	1425	1430	5507	5508
3314.01.020	1430	1440	5508	5515
3314.01.025	1440	1245	5515	-

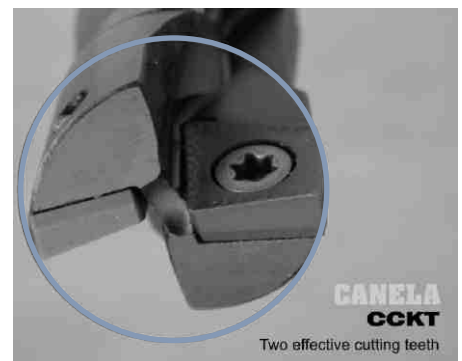
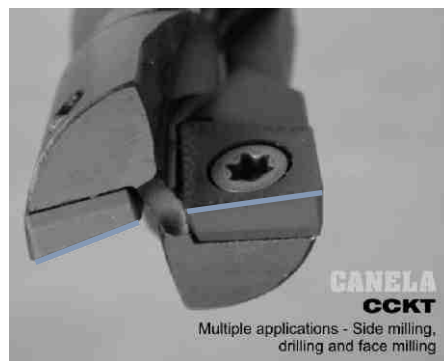

CCKT		l	s	d	Positive 7° clearance - 80° rhombic inserts. For more information see page: A.12
Ref.	CCKT 0602..	6,45	2,38	6,35	
	CCKT 0803..	8,05	3,18	7,94	
	CCKT 09T3..	9,65	4,00	9,52	
	CCKT 1204..	12,90	4,76	12,70	
	CCKT				

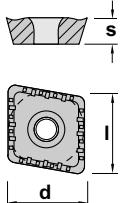

Specific applications and sets

Profile milling

Solid carbide

Drills

Boring heads

Arbors and adaptors

Specific applications and sets

For more information see page:

Contents: F.02
Sets: F.03
Tools: F.10

Inserts

Face milling cutters

Square shoulder cutters

Slot cutters

Porcupine cutters

Specific applications and sets



Characteristics:

Back draft spot facing milling cutters for flat screw heads.

The inserts are fixed by Torx screw that allow a good chip evacuation and easy use.

Applications:

Flat countersink.

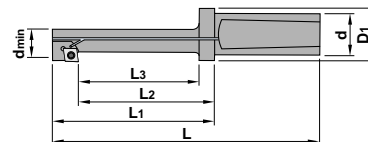
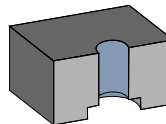
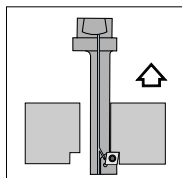

9614.61



Spot facing mills with internal coolant.

Ref.	✳	D	d _{min}	d	L	L ₁	L ₂	L ₃	D ₁	Insert size	kg
9614.61.018	1	18	10,5	20	112	62	47	40	25	CC.. 0602..	0,280
9614.61.020	1	20	13,0	20	113	63	52	45	25	CC.. 0602..	0,300
9614.61.024	1	24	15,0	20	118	68	57	50	25	CC.. 0602..	0,320
9614.61.026	1	26	17,0	20	132	82	67	60	25	CC.. 0602..	0,380
9614.61.030	1	30	19,0	20	142	92	77	65	25	CC.. 0602..	0,400
9614.61.033	1	33	21,0	20	152	102	82	75	25	CC.. 09T3..	0,430



Ref.	9614.61.018	1425	5507
	9614.61.020	1425	5507
	9614.61.024	1425	5507
	9614.61.026	1225	5507
	9614.61.030	1225	5507
	9614.61.033	1440	5515

Ref.	CC..	l	s	d	Positive 7° clearance - 80° rhombic inserts.
	CC.. 0602..	6,45	2,38	6,35	
CC.. 09T3..	9,65	3,97	9,52		
	CCGT-AL	CCKT	CCMW		

For more information see page: A.12



Characteristics:

Back draft countersink milling cutter for specific operations. The insert is fixed by Torx screw that allow a good chip evacuation and an easy use.

Applications:

This chamfering milling cutters work well on steels, alloyed steels, stainless steels and refractors. This general milling cutter for diversified manufacture is recommended for small conventional milling machines and machining centers

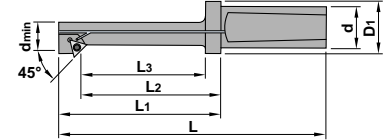
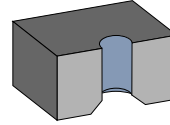
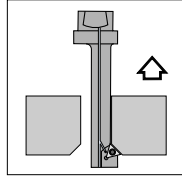

9624.61			Chamfering mills with internal coolant.									
Ref.			D	d _{min}	d	L	L ₁	L ₂	L ₃	D ₁	Insert size	
9624.61.015		1	15	10	20	105	55	42	35	25	CC.. 0602..	0,280
9624.61.020		1	20	14	20	110	60	47	40	25	CC.. 0602..	0,300
9624.61.023		1	23	17	20	120	70	57	50	25	TC.. 1102..	0,320
9624.61.027		1	27	21	20	140	90	77	70	25	TC.. 1102..	0,380
9624.61.031		1	31	24	20	150	100	87	80	25	TC.. 1102..	0,400

Ref.		
9624.61.015	1425	5507
9624.61.020	1425	5507
9624.61.023	1225	5507
9624.61.027	1225	5507
9624.61.031	1225	5507

	CC.. / TC..				CC.. Positive 7° clearance - 80° rhombic inserts. For more information see page: A.12 TC.. Positive 7° clearance - Triangular inserts. For more information see page: A.20			
	Ref.	CC.. 0602..	l	s				d
		TC.. 1102..	11,00	2,38	6,35			
	CCGT-AL	CCKT	CCMW	TCGT-AL	TCMT-39	TCMW		

Specific applications and sets

Profile milling

Solid carbide

Drills

Boring heads

Arbors and adaptors