

Boring bar



Boring bars

Technical information	C.02
Applications	C.04
Top clamp boring bars	C.06
Dimple lock	C.10
Wedge clamp / Double lock boring bars	C.12
Lever lock boring bars	C.21
Center screw boring bars	C.30
Anti-vibration tools	C.48
Sets	C.58
Cutting speed	C.62
Special tools	C.63

General turning

Aluminium wheel turning

Automatic lathes

Ceramic tools

Parting and grooving

Threading

Drills

Cartridges

Brazed tools

Tooling

Inserts

General turning

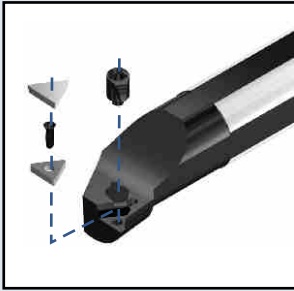

(C) Top clamp

The classic positive insert clamping system is designed to hold flat positive inserts, both with additional or sintered chipbreaker.

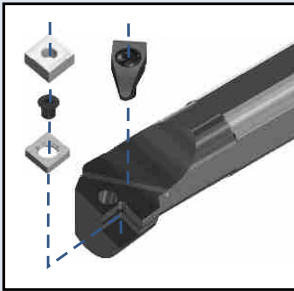

(D) Dimple lock

The "D" clamping system avoid insert movement during high feed or heavily interrupted machining, due to its accurate indexing that holds the insert securely clamped.

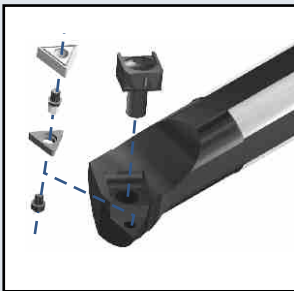
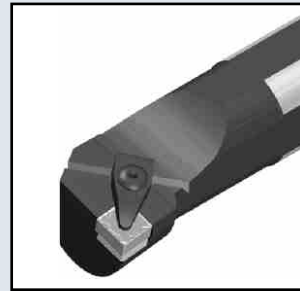

(M) Wedge clamp

Negative inserts require good clamping force for heavy duty work, for this purpose we have designed our "M" system, one of the strongest and safest available.

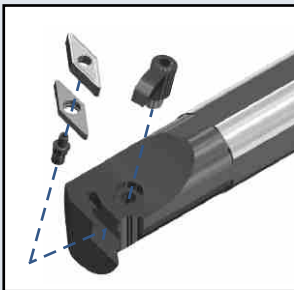

(M-K) Double lock

The double lock system offers good rigidity in negative inserts clamping, it is the first choice for center hole negative ceramic and cermet inserts.

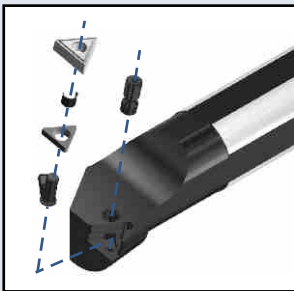

(P) Lever lock

The classic lever lock system allows a wide range of applications, it is the first choice for general purpose turning boring bars.

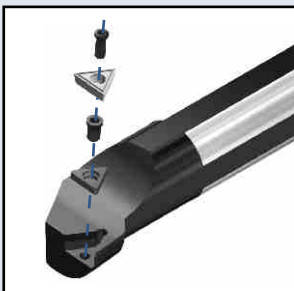

(S) Center screw

Since the advent of the TORX screw it has been possible to hold with complete safety positive inserts with centre hole. Our range covers all the screw fixing permutations.



S 25 T S D U C R 11 - EX

1 2 3 4 5 6 7 8 9 10

1

Type of bar			
A	Steel shank with internal coolant.		
H	Anti-vibration shank (Heavy metal)		
J	Anti-vibration shank (heavy metal) with internal coolant		
S	Steel shank		

2

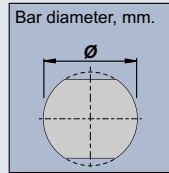

3

Bar length, mm.

H	100	T	300
J	110	U	350
K	125	V	400
L	140	W	450
M	150	Y	500
Q	180	X	Special
R	200		
S	250		

4

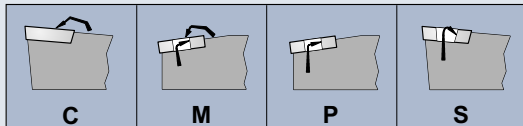

6

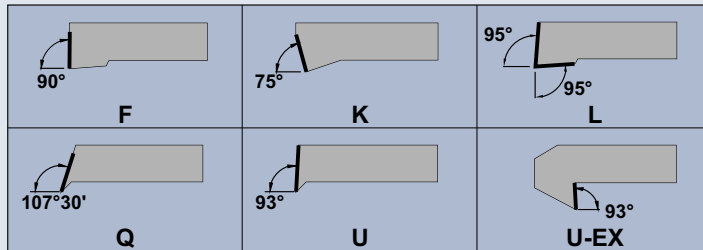

5

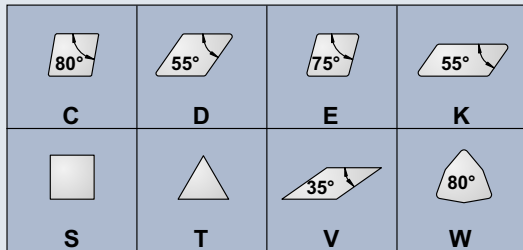

7

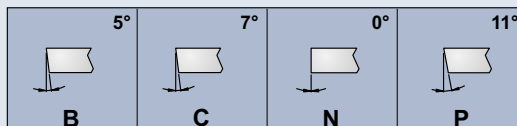

8

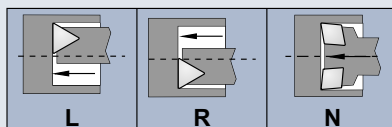

10

Manufacturer's option

9

Cutting edge length, mm.

General turning

Aluminium wheel turning

Automatic lathes

Ceramic tools

Parting and grooving

Threading

Drills

Cartridges

Brazed tools

Tooling

Inserts

General turning

Top clamp boring bars

CKUN 93°

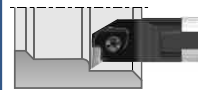

Page C.06 KNUX 1604..

CSKP 75°



Page C.07 SP.. 0903..
 SP.. 1203..
 SP.. 1904..

CTFP 90°



Page C.08 TP.. 0902..
 TP.. 1103..
 TP.. 1603..
 TP.. 2204..

CTUP 93°



Page C.09 TP.. 0902..
 TP.. 1103..
 TP.. 1603..
 TP.. 2204..

Dimple lock boring bars

DCLN 95°

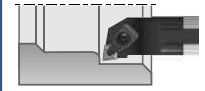

Page C.10 CN.. 1204..

DDUN 93°



Page C.11 DN.. 1506..

Wedge clamp / Double lock boring bars

MCLN-K 95°

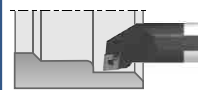

Page C.12 CN.. 1204..

MDUN-K 93°

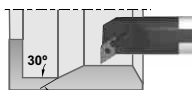

Page C.13 DN.. 1506..

MSKN-K 75°



Page C.14 SNM.. 1204..

MTFN 90°



Page C.15 TNM.. 1604..
 TNM.. 2204..

MTFN-K 90°



Page C.16 TNM.. 1604..

MTUN 93°



Page C.17 TNM.. 1604..
 TNM.. 2204..

MVUN-K 93°

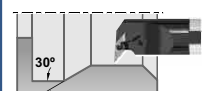

Page C.18 VN.. 1604..

MWLN 95°

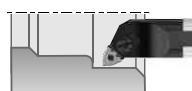

Page C.19 WNM.. 0604..
 WNM.. 0804..

MWLN-K 95°



Page C.20 WNM.. 0804..

Lever lock boring bars

PCKN 75°

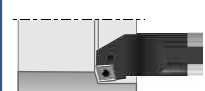

Page C.21 CN.. 1204..
 CN.. 1606..
 CN.. 1906..

PCLN 95°

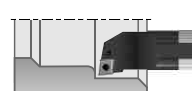

Page C.22 CN.. 0903..
 CN.. 1204..
 CN.. 1606..
 CN.. 1906..

PDUN 93°

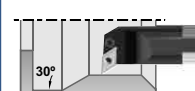

Page C.23 DN.. 1104..
 DN.. 1506..

PDUN 93°-EX

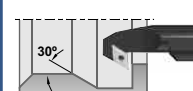

Page C.24 DN.. 1506..

PSKN 75°



Page C.25 SNM.. 1204..
 SNM.. 1906..

PSSN 45°



Page C.26 SNM.. 1204..

PTFN 90°







Page C.27 TNM.. 1604..
 TNM.. 2204..

PWLN 95°



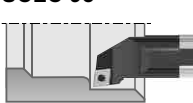

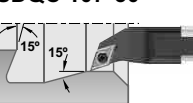
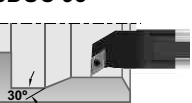
Page C.28 WNM.. 0604..
 WNM.. 0804..

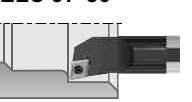
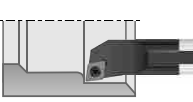
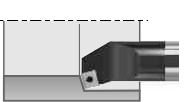
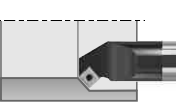
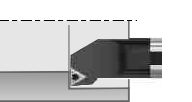
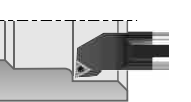
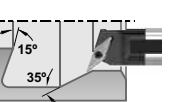
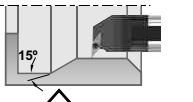
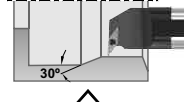

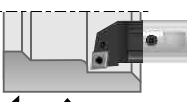
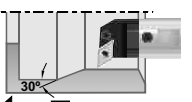
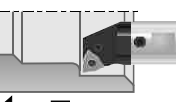
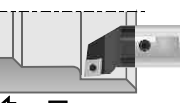
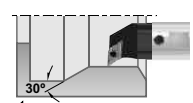
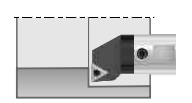
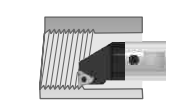

Center screw boring bars

<p>SCLC 95°</p>  <p>Page C.30 CC.. 0602.. CC.. 09T3.. CC.. 1204..</p>	<p>SCLCN 95°</p>  <p>Page C.32 CC.. 0602.. CC.. 09T3.. CC.. 1204..</p>	<p>SDQC 107°30'</p>  <p>Page C.33 DC.. 0702.. DC.. 11T3..</p>	<p>SDUC 93°</p>  <p>Page C.34 DC.. 0702.. DC.. 11T3..</p>	<p>SDUC 93°-EX</p>  <p>Page C.36 DC.. 0702.. DC.. 11T3..</p>	<p>SELC 97°30'</p>  <p>Page C.38 ECMT 0602.. ECMT 0803..</p>
<p>SELP 97°30'</p>  <p>Page C.39 EPM.. 0402.. EPM.. 0803..</p>	<p>SSKC 75°</p>  <p>Page C.40 SC.. 09T3.. SC.. 1204..</p>	<p>SSSC 45°</p>  <p>Page C.41 SC.. 09T3..</p>	<p>STFC 90°</p>  <p>Page C.42 TC.. 0902.. TC.. 1102.. TC.. 16T3..</p>	<p>STUC 93°</p>  <p>Page C.44 TC.. 1102.. TC.. 16T3..</p>	<p>SVQC 107°30'</p>  <p>Page C.45 VC.. 1103.. VC.. 1303.. VC.. 1604..</p>
<p>SVUB 93°</p>  <p>Page C.46 VBMT 1604..</p>	<p>SVUC 93°</p>  <p>Page C.47 VC.. 1103.. VC.. 1604..</p>				

Anti-vibration tools

<p>JX</p>  <p>Page C.48</p>	<p>MTUN 93°</p>  <p>Page C.49 TNM.. 1604.. TNM.. 2204..</p>	<p>PCLN 95°</p>  <p>Page C.50 CN.. 1204.. CN.. 1606..</p>	<p>PDUN 93°</p>  <p>Page C.51 DN.. 1506..</p>	<p>PWLN 95°</p>  <p>Page C.52 WNM.. 0804..</p>	<p>SCLC 95°</p>  <p>Page C.53 CC.. 09T3.. CC.. 1204..</p>
<p>SDUC 93°</p>  <p>Page C.54 DC.. 11T3..</p>	<p>STFC 90°</p>  <p>Page C.55 TC.. 16T3..</p>	<p>SXFN 90°</p>  <p>Page C.56 16 NR/L.. 22 NR/L..</p>			

Sets

<p>SET SCLC 95°</p>  <p>Page C.58 CC.. 0602..</p>	<p>SET SDQC 107°30'</p>  <p>Page C.59 DC.. 0702..</p>	<p>SET SDUC 93°</p>  <p>Page C.60 DC.. 0702..</p>	<p>SET STFC 90°</p>  <p>Page C.61 TC.. 1102..</p>		
---	---	---	---	--	--

General turning

Aluminum wheel turning

Automatic lathes

Ceramic tools

Parting and grooving

Threading

Drills

Cartridges

Brazed tools

Tooling

Inserts

General turning



Characteristics:

Boring bar for internal turning and profiling operations equipped with KNUX super-positive insert that generates low cutting forces. The top clamp ensures good stability and good rigidity.

Applications:

Profiling boring bar for semi-finishing and finishing operations.

Axial: -6°
Radial: -10°

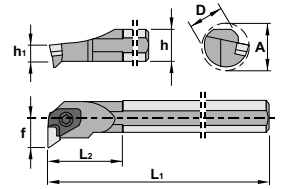

CKUN 93°

Ref.		D	h	h1	L1	L2	f	A	Insert size	Kg
	S25T CKUN R/L 16	25	23	11,5	300	50	20,5	37	KNUX 1604..	0,700
	S32U CKUN R/L 16	32	30	15,0	350	54	22,0	39	KNUX 1604..	2,050
	S40V CKUN R/L 16	40	37	18,5	400	60	27,0	48	KNUX 1604..	3,750
	S50W CKUN R/L 16	50	47	23,5	450	65	35,0	61	KNUX 1604..	6,500

Ref.								
	S25T CKUN L 16	2316	1614	5004	4295	4201	-	-
	S32U CKUN L 16	2316	1614	5004	4295	4202	3226	4012
	S40V CKUN L 16	2316	1614	5004	4295	4204	3226	4012
	S50W CKUN L 16	2316	1614	5004	4295	4204	3226	4012
	S25T CKUN R 16	2326	1614	5004	4295	4201	-	-
	S32U CKUN R 16	2326	1614	5004	4295	4202	3236	4012
	S40V CKUN R 16	2326	1614	5004	4295	4204	3236	4012
	S50W CKUN R 16	2326	1614	5004	4295	4204	3236	4012

	KNUX				Negative KNUX inserts.
	Ref.	l	s	d	
	KNUX 1604..	16,00	4,76	9,52	
	KNUX				

For more information see page: A.25



Characteristics:

Boring bar for internal turning applications equipped with square positive inserts and strong cutting edges. The top clamp ensures good rigidity and stability.

Applications:

Internal turning boring bar for all kind of materials. The workpiece should be stable.

For interrupted cut choose boring bars Ref. PSKN (Page: C.25).

Axial: 6.5°
Radial: -1.25°

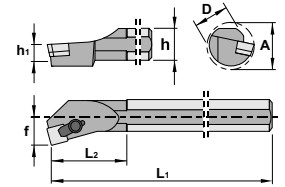

CSKP 75°

Ref.		D	h	h1	L1	L2	f	A	Insert size	Kg
S16R CSKP R/L 09	S16R CSKP R/L 09	16	15	7,5	200	30	11	20	SP.. 0903..	0,300
	S20S CSKP R/L 09	20	18	9,0	250	35	13	24	SP.. 0903..	0,550
S25T CSKP R/L 12	S25T CSKP R/L 12	25	23	11,5	300	40	17	31	SP.. 1203..	1,050
	S32U CSKP R/L 12	32	30	15,0	350	50	22	39	SP.. 1203..	2,050
	S40V CSKP R/L 12	40	37	18,5	400	60	27	48	SP.. 1203..	3,650
	S50W CSKP R/L 12	50	47	23,5	450	65	35	61	SP.. 1203..	6,450
	S50W CSKP R/L 19	50	47	23,5	450	65	35	61	SP.. 1904..	6,400

Ref.						
S16R CSKP R/L 09	S16R CSKP R/L 09	2107	5025	-	-	9009
	S20S CSKP R/L 09	2107	5025	-	-	9012-9112
S25T CSKP R/L 12	S25T CSKP R/L 12	2109	5003	-	-	2309 9012-9112
	S32U CSKP R/L 12	2209	5003	3112	4002	2309 9012-9112
	S40V CSKP R/L 12	2209	5003	3112	4002	2409 9012-9112
	S50W CSKP R/L 12	2209	5003	3112	4002	2409 9012-9112
	S50W CSKP R/L 19	2211	5004	3119	4012	2411 9019-9119

Supplementary accessories

Ref.	SP..	l	s	d	Positive 11° clearance - Square inserts.
	SP.. 0903..	9,52	3,18	9,52	
SP.. 1203..	12,70	3,18	12,70		
SP.. 1904..	19,05	4,76	19,05		

SPMR-33	SPUN				

For more information see page: A.28

General turning

Aluminium wheel turning

Automatic lathes

Ceramic tools

Parting and grooving

Threading

Drills

Cartridges

Brazed tools

Tooling

Inserts

General turning



Characteristics:

Boring bar for internal turning applications equipped with triangular positive inserts and strong cutting edges. The top clamp ensures good rigidity and stability.

Applications:

Internal turning boring bar for all kind of materials. The workpiece should be stable.

For interrupted cut choose boring bars Ref. MTFN (Page: C.15) or PTFN (Page: C.27)

Axial: +6°
Radial: 0°

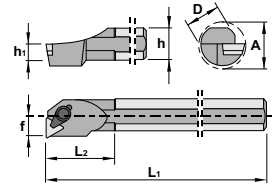

CTFP 90°

Ref.		D	h	h1	L1	L2	f	A	Insert size	Kg
S10M CTFP R/L 09		10	9	4,5	150	25	7	13	TP.. 0902..	0,060
	S12M CTFP R/L 09	12	11	5,5	150	25	9	16	TP.. 0902..	0,150
S12M CTFP R/L 11		12	11	5,5	150	25	9	16	TP.. 1103..	0,150
S16R CTFP R/L 11		16	15	7,5	200	30	11	20	TP.. 1103..	0,300
S20S CTFP R/L 11		20	18	9,0	250	35	13	24	TP.. 1103..	0,550
S16R CTFP R/L 16		16	15	7,5	200	30	11	20	TP.. 1603..	0,300
S20S CTFP R/L 16		20	18	9,0	250	35	13	24	TP.. 1603..	0,550
S25T CTFP R/L 16		25	23	11,5	300	40	17	31	TP.. 1603..	0,700
S32U CTFP R/L 16		32	30	15,0	350	50	22	39	TP.. 1603..	2,050
S40V CTFP R/L 16		40	37	18,5	400	60	27	48	TP.. 1603..	3,750
S50W CTFP R/L 16		50	47	23,5	450	65	35	61	TP.. 1603..	6,500
S40V CTFP R/L 22		40	37	18,5	400	60	27	48	TP.. 2204..	3,750
S50W CTFP R/L 22		50	47	23,5	450	65	35	61	TP.. 2204..	6,500

Ref.						
S10M CTFP R/L 09	2000	5015	-	-	-	-
S12M CTFP R/L 09	2000	5015	-	-	-	-
S12M CTFP R/L 11	2304	5025	-	-	-	-
S16R CTFP R/L 11	2107	5025	-	-	2307	9011-9111
S20S CTFP R/L 11	2107	5025	-	-	2307	9011-9111
S16R CTFP R/L 16	2119	5003	-	-	2309	9016-9116
S20S CTFP R/L 16	2119	5003	-	-	2309	9016-9116
S25T CTFP R/L 16	2109	5003	-	-	2309	9016-9116
S32U CTFP R/L 16	2209	5003	3116	4002	2309	9016-9116
S40V CTFP R/L 16	2209	5003	3116	4002	2409	9016-9116
S50W CTFP R/L 16	2209	5003	3116	4002	2409	9016-9116
S40V CTFP R/L 22	2211	5004	3122	4012	2411	9022-9122
S50W CTFP R/L 22	2211	5004	3122	4012	2411	9022-9122

Supplementary accessories

Ref.	TP..	l	s	d	Positive 11° clearance - Triangular inserts
	TP.. 0902..	9,62	2,38	5,55	
TP.. 1103..	11,00	3,18	6,35		
TP.. 1603..	16,50	3,18	9,52		
TP.. 2204..	22,00	4,76	12,70		

For more information see page: A.31

TPMN	TPMR-33	TPUN	TPUX-R	TPUX-L



Characteristics:

Boring bar for internal turning applications equipped with triangular positive inserts and strong cutting edges. The top clamp ensures good rigidity and stability.

Applications:

Internal turning boring bar for all kind of materials. The workpiece should be stable.

For interrupted cut choose boring bars Ref. MTUN (Page: C.17)

Axial: 0°
Radial: -6°

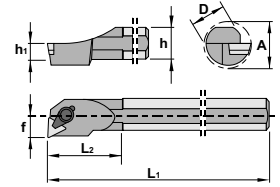
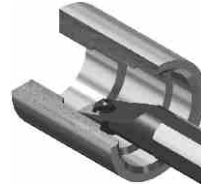

CTUP 93°

Ref.		D	h	h1	L1	L2	f	A	Insert size	
S10M CTUP R/L 09	S10M CTUP R/L 09	10	9	4,5	150	25	7	13	TP.. 0902..	0,060
	S12M CTUP R/L 09	12	11	5,5	150	25	9	16	TP.. 0902..	0,150
S12M CTUP R/L 11	S12M CTUP R/L 11	12	11	5,5	150	25	9	16	TP.. 1103..	0,150
	S16R CTUP R/L 11	16	15	7,5	200	30	11	20	TP.. 1103..	0,300
S20S CTUP R/L 11	S20S CTUP R/L 11	20	18	9,0	250	35	13	24	TP.. 1103..	0,550
S16R CTUP R/L 16	S16R CTUP R/L 16	16	15	7,5	200	30	11	20	TP.. 1603..	0,300
	S20S CTUP R/L 16	20	18	9,0	250	35	13	24	TP.. 1603..	0,550
S25T CTUP R/L 16	S25T CTUP R/L 16	25	23	11,5	300	40	17	31	TP.. 1603..	0,700
S32U CTUP R/L 16	S32U CTUP R/L 16	32	30	15,0	350	50	22	39	TP.. 1603..	2,050
S40V CTUP R/L 16	S40V CTUP R/L 16	40	37	18,5	400	60	27	48	TP.. 1603..	3,750
S50W CTUP R/L 16	S50W CTUP R/L 16	50	47	23,5	450	65	35	61	TP.. 1603..	6,500
S40V CTUP R/L 22	S40V CTUP R/L 22	40	37	18,5	400	60	27	48	TP.. 2204..	3,750
S50W CTUP R/L 22	S50W CTUP R/L 22	50	47	23,5	450	65	35	61	TP.. 2204..	6,500

Ref.							
S10M CTUP R/L 09	2000	5015	-	-	-	-	-
S12M CTUP R/L 09	2000	5015	-	-	-	-	-
S12M CTUP R/L 11	2304	5025	-	-	-	-	-
S16R CTUP R/L 11	2107	5025	-	-	2307	9011-9111	-
S20S CTUP R/L 11	2107	5025	-	-	2307	9011-9111	-
S16R CTUP R/L 16	2119	5003	-	-	2309	9016-9116	-
S20S CTUP R/L 16	2119	5003	-	-	2309	9016-9116	-
S25T CTUP R/L 16	2109	5003	-	-	2309	9016-9116	-
S32U CTUP R/L 16	2209	5003	3116	4002	2309	9016-9116	-
S40V CTUP R/L 16	2209	5003	3116	4002	2409	9016-9116	-
S50W CTUP R/L 16	2209	5003	3116	4002	2409	9016-9116	-
S40V CTUP R/L 22	2211	5004	3122	4012	2411	9022-9122	-
S50W CTUP R/L 22	2211	5004	3122	4012	2411	9022-9122	-

Supplementary accessories

Ref.	TP..	l	s	d	Positive 11° clearance - Triangular inserts
	TP.. 0902..	9,62	2,38	5,55	
TP.. 1103..	11,00	3,18	6,35		
TP.. 1603..	16,50	3,18	9,52		
TP.. 2204..	22,00	4,76	12,70		

For more information see page: A.31

TPMN	TPMR-33	TPUN	TPUX-R	TPUX-L

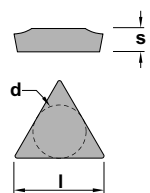

Inserts

General turning



Characteristics:

Boring bar for internal turning applications equipped with rhombic negative inserts (angle 80°) and strong cutting edges. The dimple lock ensures good rigidity and chip flow in roughing applications.

Applications:

Internal boring bar for general applications, roughing, semi-finishing and finishing. For low powered machines and small pieces choose boring bars Ref. SCLC (Page: C.30).

Axial: -5°
Radial: -13.5°

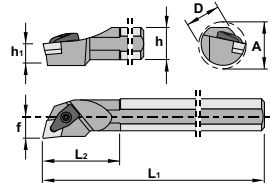

DCLN 95°

Characteristics:
 Boring bars with steel shank.

Ref.	D	h	h1	L1	L2	f	A	Insert size	Kg
S25T DCLN R/L 12	25	23	11,5	300	40	17	31	CN.. 1204..	0,700
S32U DCLN R/L 12	32	30	15,0	350	50	22	39	CN.. 1204..	2,050
S40V DCLN R/L 12	40	37	18,5	400	60	27	48	CN.. 1204..	3,750



Ref.	S25T DCLN R/L 12	3612	1765	2312	1907	4295	5004
	S32U DCLN R/L 12	ICSN-432	1161	2312	1907	4295	5004
	S40V DCLN R/L 12	ICSN-432	1160	2312	1907	4295	5004

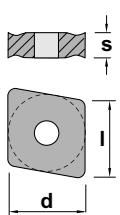

CN..

l

s

d

Negative 80° rhombic inserts.

For more information see page: A.18

Ref.	CN.. 1204..	12,90	4,76	12,70
------	-------------	-------	------	-------

CNMG-CF **CNMG-CM** **CNMG-CR** **CNMG-CS**



CNGP

CNMA

CNMG-CFM

CNMG-CFC

CNMG-CMC

CNMG-CMF

CNMG-CMR

CNMM





Characteristics:

Boring bar for internal turning and profiling applications equipped with rhombic negative inserts (angle 55°) and strong cutting edges.

The dimple lock ensures good rigidity and chip flow in roughing applications.

Applications:

Profiling boring bar for general applications, roughing, semi-finishing and finishing.

For low powered machines and small pieces choose boring bars Ref. SDUC (Page: C.34).

Axial: -6°
Radial: -14°

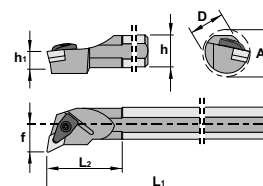

DDUN 93°		Characteristics: Boring bars with steel shank.								
Ref.		D	h	h1	L1	L2	f	A	Insert size	Kg
	S32U DDUN R/L 15	32	30	15,0	350	50	22	39	DN.. 1506..	2,050
	S40V DDUN R/L 15	40	37	18,5	400	60	27	48	DN.. 1506..	3,750

Ref.						
S32U DDUN R/L 15	IDSN 432	1161	2312	1907	4294	5004
S40V DDUN R/L 15	IDSN 432	1160	2312	1907	4294	5004

	DN..				Negative 55° rhombic inserts. For more information see page: A.22				
	Ref.	DN.. 1506..	l	s	d	DNMG-CF	DNMG-CM		
			15,50	6,35	12,70				
	DNGP	DNMA	DNMG-CFM	DNMG-CMR	DNMX				

General turning

Aluminium wheel turning

Automatic lathes

Ceramic tools

Parting and grooving

Threading

Drills

Cartridges

Brazed tools

Tooling

Inserts

General turning



Characteristics:

Multipurpose boring bar equipped with rhombic negative double side insert (angle 80°) with strong cutting edge. The center pin and top clamp ensure good rigidity and stability in roughing applications.

Applications:

Internal boring bar for general applications, roughing, semi-finishing and finishing. Specially recommended for cermet, ceramic and K10, P10 grade inserts.

For low powered machines and small pieces choose boring bars Ref. SCLC (Page: C.30).

Axial: -5°
Radial: -13.5°

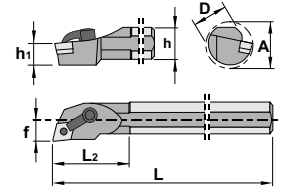

MCLN-K 95°

Ref.		D	h	h1	L1	L2	f	A	Insert size	Kg
S25T MCLN R/L 12-K		25	23	11,5	300	33	17	31	CN.. 1204..	0,700
S32U MCLN R/L 12-K		32	30	15,0	350	50	22	39	CN.. 1204..	2,050
S40V MCLN R/L 12-K		40	37	18,5	400	60	27	48	CN.. 1204..	3,750

Ref.							
S25T MCLN R/L 12-K		2613	1186	5003	-	1686	5025
S32U MCLN R/L 12-K		2613	1086	5003	ICSN-432	1656	5025
S40V MCLN R/L 12-K		2613	1086	5003	ICSN-432	1656	5025

	CN..				Negative 80° rhombic inserts.			
	Ref.	l	s	d	For more information see page: A.18			
	CN.. 1204..	12,90	4,76	12,70	CNMG-CF	CNMG-CM	CNMG-CR	CNMG-CS
	CNGP	CNMA	CNMG-CFM	CNMG-CFC	CNMG-CMC	CNMG-CMF	CNMG-CMR	CNMM



Characteristics:

Internal turning and profiling boring bar equipped with rhombic negative double side insert (angle 55°) with strong cutting edge. The center pin and top clamp ensure good rigidity and stability in roughing applications.

Applications:

Internal boring bar for general applications, roughing, semi-finishing and finishing.

For low powered machines and small pieces choose boring bars Ref. SDUC (Page: C.34).

Axial: -6°
Radial: -12°

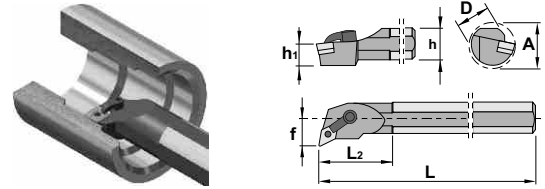

MDUN-K 93°

Ref.		D	h	h1	L1	L2	f	A	Insert size	Kg
S25T MDUN R/L 15-K		25	23	11,5	300	40	17	31	DN.. 1506..	0,700
S32U MDUN R/L 15-K		32	30	15,0	350	50	22	39	DN.. 1506..	2,050
S40V MDUN R/L 15-K		40	37	18,5	400	60	27	48	DN.. 1506..	3,750

General turning

Aluminium wheel turning

Automatic lathes

Ceramic tools

Parting and grooving

Threading

Drills

Cartridges

Brazed tools

Tooling

Ref.	S25T MDUN R/L 15-K	S32U MDUN R/L 15-K	S40V MDUN R/L 15-K						
	2614	1186	5003	IDSN-432	1686	5025			
	2614	1086	5003	IDSN-432	1666	5025			
	2614	1086	5003	IDSN-432	1666	5025			

	DN..				Negative 55° rhombic inserts.		For more information see page: A.22				
	Ref.	DN.. 1506..	l	s	d	DNMG-CF	DNMG-CM				
			15,50	6,35	12,70						
	DNGP	DNMA	DNMG-CFM	DNMG-CMR	DNMX						

Inserts

General turning



Characteristics:

Boring bar for internal turning applications equipped with square negative inserts and strong cutting edges. The center pin and top clamp ensure good rigidity and stability in roughing applications.

Applications:

Internal boring bar for general applications, roughing, semi-finishing and finishing.

For low powered machines and small pieces choose boring bars Ref. CSKP (Page: C.07) or SSKC (Page: C.40).

Axial: -3.25°
Radial: -11°

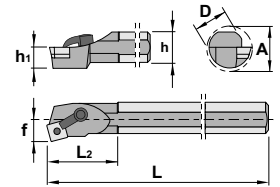

MSKN-K 75°

Ref.		D	h	h1	L1	L2	f	A	Insert size	Kg
Ref.	S32U MSKN R/L 12-K	32	33	15,0	350	50	22	39	SNM.. 1204..	2,050
	S40V MSKN R/L 12-K	40	37	18,5	400	60	27	48	SNM.. 1204..	3,750

Ref.							
Ref.	S32U MSKN R/L 12-K	2613	1086	5003	ISSN-432	1656	5025
	S40V MSKN R/L 12-K	2613	1086	5003	ISSN-432	1656	5025

	SNM..				Negative square inserts.				
	Ref.	SNM.. 1204..	l	s	d	For more information see page: A.27			
						SNMG-CR			



Characteristics:

Internal turning and profiling boring bar equipped with triangular negative double side insert with strong cutting edge. The center pin and top clamp ensure good rigidity and stability in roughing applications.

Applications:

Internal boring bar for general applications, roughing, semi-finishing and finishing.
Not suitable for cermet, ceramic and K10, P10 grade inserts.

For low powered machines and small pieces choose boring bars Ref. CTFP (Page: C.08) or STFC (Page: C.42).

Axial: -6°
Radial: -12°

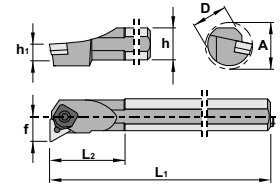

MTFN 90°

Ref.		D	h	h1	L1	L2	f	A	Insert size	Kg
S25T MTFN R/L 16	S25T MTFN R/L 16	25	23	11,5	300	40	17	34	TNM.. 1604..	0,700
	S32U MTFN R/L 16	32	30	15,0	350	50	22	39	TNM.. 1604..	2,050
	S40V MTFN R/L 16	40	37	18,5	400	60	27	48	TNM.. 1604..	3,750
	S50W MTFN R/L 16	50	47	23,5	450	65	35	61	TNM.. 1604..	6,500
S40V MTFN R/L 22	S40V MTFN R/L 22	40	37	18,5	400	60	27	48	TNM.. 2204..	3,750
	S50W MTFN R/L 22	50	47	23,5	450	65	35	61	TNM.. 2204..	6,500

General turning

Aluminium
wheel turning

Automatic lathes

Ceramic tools

Parting and
grooving

Threading

Drills

Cartridges

Brazed tools

Tooling

Ref.					
S25T MTFN R/L 16	2014	5005	3414	1644	1813
S32U MTFN R/L 16	2014	5005	3414	1644	1393
S40V MTFN R/L 16	2014	5005	3414	1644	1393
S50W MTFN R/L 16	2014	5005	3414	1644	1393
S40V MTFN R/L 22	2024	5005	ITSN-433	1661	1394
S50W MTFN R/L 22	2024	5005	ITSN-433	1661	1394

Ref.	TNM..				Negative triangular inserts.		
	l	s	d	For more information see page: A.29			
	TNM.. 1604..	TNM.. 2204..		TNMG-CF	TNMG-CM	TNMG-CS	
	16,50	22,00	4,76	9,52			
	TNMA	TNMG-CFC	TNMG-CFM	TNMG-CMC	TNMG-CMF	TNMG-CMR	TNMX

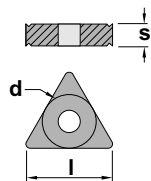

Inserts

General turning



Characteristics:

Internal turning and profiling boring bar equipped with triangular negative double side insert with strong cutting edge. The center pin and top clamp ensure good rigidity and stability in roughing applications.

Applications:

Internal boring bar for general applications, roughing, semi-finishing and finishing. Specially recommended for cermet, ceramic and K10, P10 grade inserts.

For low powered machines and small pieces choose boring bars Ref. CTFP (Page: C.08) or STFC (Page: C.42).

Axial: -6°
Radial: -11°

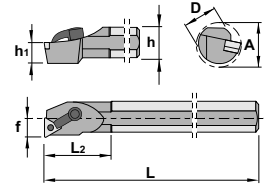

MTFN-K 90°

Ref.		D	h	h1	L1	L2	f	A	Insert size	Kg
S25T MTFN R/L 16-K		25	23	11,5	300	40	17	31	TNM.. 1604..	0,700
S32U MTFN R/L 16-K		32	30	15,0	350	50	22	39	TNM.. 1604..	2,050
S40V MTFN R/L 16-K		40	37	18,5	400	60	27	48	TNM.. 1604..	3,750

Ref.							
S25T MTFN R/L 16-K		2613	1086	5003	ITSN-322	1665	5002
S32U MTFN R/L 16-K		2613	1086	5003	ITSN-322	1665	5002
S40V MTFN R/L 16-K		2613	1086	5003	ITSN-322	1665	5002

	TNM..				Negative triangular inserts.		
	Ref.	l	s	d	For more information see page: A.29		
	TNM.. 1604..	16,50	4,76	9,52	TNMG-CF	TNMG-CM	TNMG-CS
	TNMA	TNMG-CFC	TNMG-CFM	TNMG-CMC	TNMG-CMF	TNMG-CMR	TNMX



Characteristics:

Internal turning and profiling boring bar equipped with triangular negative double side insert with strong cutting edge. The center pin and top clamp ensure good rigidity and stability in roughing applications.

Applications:

Internal boring bar for general applications, roughing, semi-finishing and finishing.
Not suitable for cermet, ceramic and K10, P10 grade inserts.

For low powered machines and small pieces choose boring bars Ref. CTUP (Page: C.09) or STUC (Page: C.44).

Axial: -6°
Radial: -11°

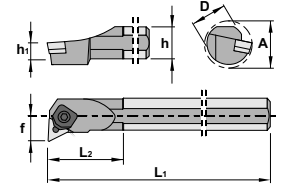

MTUN 93°

Ref.		D	h	h1	L1	L2	f	A	Insert size	⚖️ Kg
S25T MTUN R/L 16	S25T MTUN R/L 16	25	23	11,5	300	40	17	34	TNM.. 1604..	0,700
	S32U MTUN R/L 16	32	30	15,0	350	50	22	39	TNM.. 1604..	2,050
	S40V MTUN R/L 16	40	37	18,5	400	60	27	48	TNM.. 1604..	3,750
	S50W MTUN R/L 16	50	47	23,5	450	65	35	61	TNM.. 1604..	6,500
S40V MTUN R/L 22	S40V MTUN R/L 22	40	37	18,5	400	60	27	48	TNM.. 2204..	3,750
	S50W MTUN R/L 22	50	47	23,5	450	65	35	61	TNM.. 2204..	6,500

General turning

Aluminium wheel turning

Automatic lathes

Ceramic tools

Parting and grooving





Threading











Drills

Cartridges

Brazed tools

Tooling

Ref.						
S25T MTUN R/L 16	S25T MTUN R/L 16	2014	5005	3414	1644	1813
	S32U MTUN R/L 16	2014	5005	3414	1644	1393
	S40V MTUN R/L 16	2014	5005	3414	1644	1393
	S50W MTUN R/L 16	2014	5005	3414	1644	1393
S40V MTUN R/L 22	S40V MTUN R/L 22	2024	5005	ITSN-433	1661	1394
	S50W MTUN R/L 22	2024	5005	ITSN-433	1661	1394

Ref.	TNM..				Negative triangular inserts.		
	l	s	d	For more information see page: A.29			
	TNM.. 1604..	TNM.. 2204..		TNMG-CF	TNMG-CM	TNMG-CS	
	16,50	22,00	4,76	9,52			
							
	TNMA	TNMG-CFC	TNMG-CFM	TNMG-CMC			
							

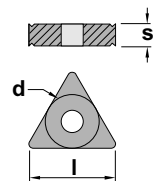

Inserts

General turning



Characteristics:

Internal turning and profiling boring bar equipped with rhombic negative double side insert (angle 35°) with strong cutting edge. The center pin and top clamp ensure good rigidity and stability in roughing applications.

Applications:

Internal boring bar for general applications, roughing, semi-finishing and finishing.

For low powered machines and small pieces choose boring bars Ref. SVUC (Page: C.47).

Axial: -5°
Radial: -15°

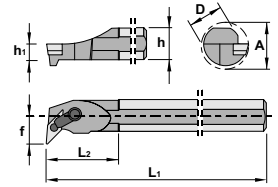

MVUN-K 93°

Ref.		D	h	h1	L1	L2	f	A	Insert size	Kg
S25T MVUN R/L 16-K		25	23	11,5	300	40	17	31	VN.. 1604..	0,700
S32U MVUN R/L 16-K		32	30	15,0	350	50	22	39	VN.. 1604..	2,050
S40V MVUN R/L 16-K		40	37	18,5	400	60	27	48	VN.. 1604..	3,750



Ref.	S25T MVUN R/L 16-K	S32U MVUN R/L 16-K	S40V MVUN R/L 16-K
	2614	2614	2614
	5003	5003	5003
	3717	3717	3717
	1186	1086	1086
	1665	1665	1665
	5002	5002	5002

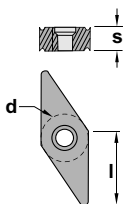

VN..

l

s

d

Negative 35° rhombic inserts

Ref.	VN.. 1604..	16,50	4,76	9,52
------	-------------	-------	------	------

For more information see page: A.33

VNGP

VNMG

VNMG-CMC





Characteristics:

Multipurpose boring bar equipped with trigon negative double side insert (angle 80°) with strong cutting edge. The center pin and top clamp ensure good rigidity and stability in roughing applications.

Applications:

Internal boring bar for general applications, roughing, semi-finishing and finishing. Not suitable for cermet, ceramic and K10, P10 grade inserts.

Axial: -5°
Radial: -11.5°

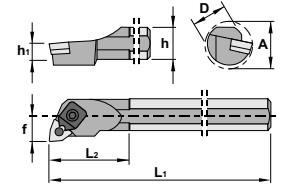
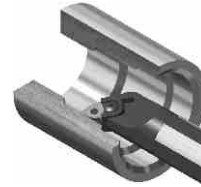

MWLN 95°

Ref.		D	h	h1	L1	L2	f	A	Insert size	
S20S MWLN R/L 06	S20S MWLN R/L 06	20	18	9,0	250	36	13	27	WNM.. 0604..	0,550
	S25T MWLN R/L 06	25	23	11,5	300	40	17	31	WNM.. 0604..	0,700
	S32U MWLN R/L 06	32	30	15,0	350	50	22	39	WNM.. 0604..	2,050
S25T MWLN R/L 08	S25T MWLN R/L 08	25	23	11,5	300	40	17	31	WNM.. 0804..	0,700
	S32U MWLN R/L 08	32	30	15,0	350	50	22	39	WNM.. 0804..	2,050
	S40V MWLN R/L 08	40	37	18,5	400	60	27	48	WNM.. 0804..	3,750
S50W MWLN R/L 08	S50W MWLN R/L 08	50	47	23,5	450	65	35	61	WNM.. 0804..	6,500

Ref.					
S20S MWLN R/L 06	2006	5025	-	1643	1813
S25T MWLN R/L 06	2006	5025	3006	1644	1813
S32U MWLN R/L 06	2006	5025	3006	1644	1393
S25T MWLN R/L 08	2011	5025	-	1647	1814
S32U MWLN R/L 08	2011	5025	IWSN-432	1661	1814
S40V MWLN R/L 08	2011	5025	IWSN-432	1661	1814
S50W MWLN R/L 08	2011	5025	IWSN-432	1661	1814

Ref.	WNM..				Negative 80° trigon inserts.		
	l	s	d	WNMG-CF	WNMG-CM	WNMG-CS	
	WNM.. 0604..	6,45	4,76	9,52			
WNM.. 0804..	8,14	4,76	12,70				
	WNMA	WNMG-CFM	WNMG-CMC	WNMG-CMF	WNMG-CMR		

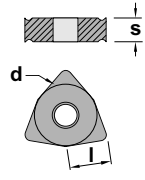

General turning

Aluminium wheel turning

Automatic lathes

Ceramic tools

Parting and grooving

Threading

Drills

Cartridges

Brazed tools

Tooling

Inserts

General turning



Characteristics:

Multipurpose boring bar equipped with trigon negative double side insert (angle 80°) with strong cutting edge. The center pin and top clamp ensure good rigidity and stability in roughing applications.

Applications:

Internal turning boring bar for general applications, roughing, semi-finishing and finishing. Specially recommended for cermet, ceramic and K10, P10 grade inserts.

Axial: -5°
Radial: -11.5°

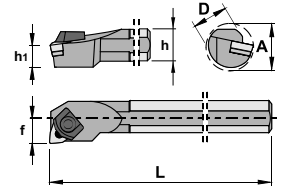

MWLN-K 95°

Ref.		D	h	h1	L1	L2	f	A	Insert size	Kg
	S25T MWLN R/L 08-K	25	23	11,5	300	40	17	31	WNM.. 0804..	0,700
	S32U MWLN R/L 08-K	32	30	15,0	350	50	22	39	WNM.. 0804..	2,050
	S40V MWLN R/L 08-K	40	37	18,5	400	60	27	48	WNM.. 0804..	3,750
	S50W MWLN R/L 08-K	50	47	23,5	450	65	35	61	WNM.. 0804..	6,500

Ref.						
	S25T MWLN R/L 08-K	2018	-	1647	5025	1814
	S32U MWLN R/L 08-K	2018	IWSN-432	1661	5025	1814
	S40V MWLN R/L 08-K	2018	IWSN-432	1661	5025	1814
	S50W MWLN R/L 08-K	2018	IWSN-432	1661	5025	1814

	WNM..				Negative 80° trigon inserts.		
	Ref.	l	s	d	For more information see page: A.34		
	WNM.. 0804..	8,14	4,76	12,70	WNMG-CF	WNMG-CM	WNMG-CS
	WNMA	WNMG-CFM	WNMG-CMC	WNMG-CMF	WNMG-CMR		



Characteristics:

Boring bar for internal turning applications equipped with rhombic negative inserts (angle 80°) and strong cutting edges.

The lever lock ensures good rigidity and chip flow in roughing applications.

Applications:

Internal boring bar for general applications, roughing, semi-finishing and finishing.

Axial: -3°
Radial: -11.5°

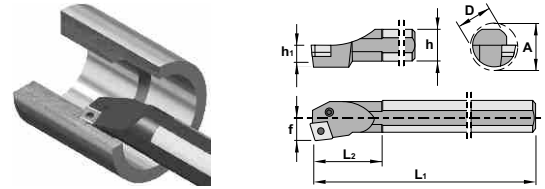

PCKN 75°

Ref.		D	h	h1	L1	L2	f	A	Insert size	
S25T PCKN R/L 12	S25T PCKN R/L 12	25	23	11,5	300	40	17	31	CN.. 1204..	0,700
	S32U PCKN R/L 12	32	30	15,0	350	50	22	39	CN.. 1204..	2,050
	S40V PCKN R/L 12	40	37	18,5	400	60	27	48	CN.. 1204..	3,750
S50W PCKN R/L 16	S50W PCKN R/L 16	50	47	23,5	450	65	35	61	CN.. 1606..	6,500
	S50W PCKN R/L 19	50	47	23,5	450	65	35	61	CN.. 1906..	6,500

Ref.							
S25T PCKN R/L 12	S25T PCKN R/L 12	8212	1626	5025	-	-	-
	S32U PCKN R/L 12	8312	1648	5003	3612	4112	0012
	S40V PCKN R/L 12	8012	1608	5003	3612	4112	0012
S50W PCKN R/L 16	S50W PCKN R/L 16	8016	1618	5003	3616	4115	0015
	S50W PCKN R/L 19	8019	1610	5004	3619	4119	0019

	CN..				Negative 80° rhombic inserts.			
	Ref.	l	s	d	For more information see page: A.18			
	CN.. 1204..	12,90	4,76	12,70	CNMG-CF	CNMG-CM	CNMG-CR	CNMG-CS
	CN.. 1606..	16,10	6,35	15,88				
	CN.. 1906..	19,30	6,35	19,05				
	CNGP	CNMA	CNMG-CFM	CNMG-CFC	CNMG-CMC	CNMG-CMF	CNMG-CMR	CNMM

General turning

Aluminium wheel turning

Automatic lathes

Ceramic tools

Parting and grooving

Threading

Drills

Cartridges

Brazed tools

Tooling

Inserts

General turning



Characteristics:

Boring bar for internal turning applications equipped with rhombic negative inserts (angle 80°) and strong cutting edges.

The lever lock ensures good rigidity and chip flow in roughing applications.

Applications:

Internal boring bar for general applications, roughing, semi-finishing and finishing.

For low powered machines and small pieces choose boring bars Ref. SCLC (Page: C.30).

Axial: -5°
Radial: -13.5°

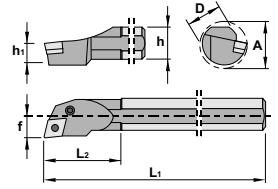

PCLN 95°

Characteristics:
 Boring bars with steel shank.

Ref.	D	h	h1	L1	L2	f	A	Insert size	
S16R PCLN R/L 09	16	15	7,5	200	26	11	20	CN.. 0903..	0,300
S20S PCLN R/L 09	20	18	9,0	250	29	13	25	CN.. 0903..	0,550
S25T PCLN R/L 09	25	23	11,5	300	33	17	32	CN.. 0903..	0,700
S25T PCLN R/L 12	25	23	11,5	300	40	17	31	CN.. 1204..	0,700
S32U PCLN R/L 12	32	30	15,0	350	50	22	39	CN.. 1204..	2,050
S40V PCLN R/L 12	40	37	18,5	400	60	27	48	CN.. 1204..	3,750
S50W PCLN R/L 12	50	47	23,5	450	65	35	61	CN.. 1204..	6,500
S50W PCLN R/L 16	50	47	23,5	450	65	35	61	CN.. 1606..	6,500
S50W PCLN R/L 19	50	47	23,5	450	65	35	61	CN.. 1906..	6,500



Ref.	S16R PCLN R/L 09	8005	1605	5002	-	-	-	-	-
	S20S PCLN R/L 09	8005	1605	5002	-	-	-	-	-
	S25T PCLN R/L 09	8009	1626	5025	3609	4109	0009	-	-
	S25T PCLN R/L 12	8212	1626	5025	-	-	-	-	-
	S32U PCLN R/L 12	8312	1648	5003	3612	4112	0012	-	-
	S40V PCLN R/L 12	8012	1608	5003	3612	4112	0012	-	-
	S50W PCLN R/L 12	8012	1608	5003	3612	4112	0012	-	-
	S50W PCLN R/L 16	8016	1618	5003	3616	4115	0015	-	-
	S50W PCLN R/L 19	8219	1610	5004	3619	4129	0019	-	-

A-PCLN 95°



Characteristics:
 Boring bars with internal coolant.

Ref.	D	h	h1	L1	L2	f	A	Insert size	
A16M PCLN R/L 09	16	15	7,5	150	26	11	20	CN.. 0903..	0,200
A20Q PCLN R/L 09	20	18	9,0	180	29	13	25	CN.. 0903..	0,400
A25R PCLN R/L 12	25	23	11,5	200	40	17	31	CN.. 1204..	0,700
A32S PCLN R/L 12	32	30	15,0	250	50	22	39	CN.. 1204..	1,400
A40T PCLN R/L 12	40	37	18,5	300	60	27	48	CN.. 1204..	2,650



Ref.	A16M PCLN R/L 09	8005	1605	5002	-	-	-	-	-
	A20Q PCLN R/L 09	8005	1605	5002	-	-	-	-	-
	A25R PCLN R/L 12	8212	1626	5025	-	-	-	-	-
	A32S PCLN R/L 12	8312	1648	5003	3612	4112	0012	-	-
	A40T PCLN R/L 12	8012	1608	5003	3612	4112	0012	-	-

Ref.	CN..				Negative 80° rhombic inserts.			
	l	s	d	CNMG-CF	CNMG-CM	CNMG-CR	CNMG-CS	
CN.. 0903..	9,65	3,18	9,52					
CN.. 1204..	12,90	4,76	12,70					
CN.. 1606..	16,10	6,35	15,88					
CN.. 1906..	19,30	6,35	19,05					
	CNGP	CNMA	CNMG-CFM	CNMG-CFC	CNMG-CMC	CNMG-CMF	CNMG-CMR	CNMM

For more information see page: A.18



Characteristics:

Boring bar for internal turning and profiling applications equipped with rhombic negative inserts (angle 55°) and strong cutting edges.

The lever lock ensures good rigidity and chip flow in roughing applications.

Applications:

Profiling boring bar for general applications, roughing, semi-finishing and finishing.

For low powered machines and small pieces choose boring bars Ref. SDUC (Page: C.34).

Axial: -6°
Radial: -14°

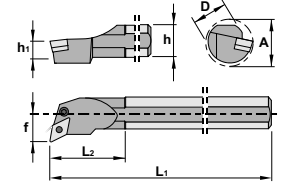

PDUN 93°		Characteristics: Boring bars with steel shank.								
Ref.		D	h	h1	L1	L2	f	A	Insert size	Kg
Ref.	S25T PDUN R/L 11	25	23	11,5	300	35	17	32	DN.. 1104..	0,700
	S32U PDUN R/L 11	32	30	15,0	350	40	22	40	DN.. 1104..	2,050
	S32U PDUN R/L 15	32	30	15,0	350	50	22	39	DN.. 1506..	2,050
	S40V PDUN R/L 15	40	37	18,5	400	60	27	48	DN.. 1506..	3,750
	S50W PDUN R/L 15	50	47	23,5	450	65	35	61	DN.. 1506..	6,500
Ref.		8009	1606	5025	3711	4109	0009	-	-	-
	S25T PDUN R/L 11	8009	1606	5025	3711	4109	0009	-	-	-
	S32U PDUN R/L 11	8415	1648	5003	3715	4112	0012	3725	4135	
	S40V PDUN R/L 15	8415	1638	5003	3715	4112	0012	3725	4135	
	S50W PDUN R/L 15	8415	1638	5003	3715	4112	0012	3725	4135	
<i>For DNM.. 1504.. inserts</i>										

A-PDUN 93°		Characteristics: Boring bars with internal coolant.								
Ref.		D	h	h1	L1	L2	f	A	Insert size	Kg
Ref.	A25R PDUN R/L 11	25	23	11,5	200	40	17	31	DN.. 1104..	0,700
	A32S PDUN R/L 15	32	30	15,0	250	50	22	39	DN.. 1506..	1,400
	A40T PDUN R/L 15	40	37	18,5	300	60	27	48	DN.. 1506..	2,650
Ref.		8009	1606	5025	3711	4109	0009	-	-	-
	A25R PDUN R/L 11	8415	1648	5003	3715	4112	0012	3725	4135	
	A32S PDUN R/L 15	8415	1638	5003	3715	4112	0012	3725	4135	
<i>For DNM.. 1504.. inserts</i>										

	DN..				Negative 55° rhombic inserts.			
	Ref.	DN.. 1104..	DN.. 1504..	DN.. 1506..	DNMG-CF	DNMG-CM	DNMG-CS	
	l	s	d					
		11,60	4,76	9,52				
		15,50	4,76	12,70				
		15,50	6,35	12,70				
	DNGP	DNMA	DNMG-CFC	DNMG-CFM	DNMG-CMC	DNMG-CMF	DNMG-CMR	DNMX

Inserts

General turning



Characteristics:

Backwards boring bar for internal turning and profiling applications equipped with rhombic negative inserts (angle 55°) and strong cutting edges. The lever lock ensures good rigidity and chip flow in roughing applications.

Applications:

Backwards profiling boring bar for general applications, roughing, semi-finishing and finishing. For low powered machines and small pieces choose boring bars Ref. SDUC-EX (Page: C.36).

Axial: -6°
Radial: -14°

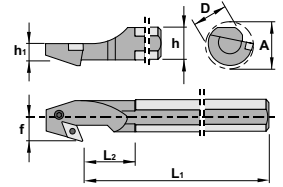

PDUN 93°-EX

Ref.	D	h	h1	L1	L2	f	A	Insert size	Kg
S32U PDUN R/L 15-EX	32	30	15,0	350	50	22	39	DN.. 1506..	2,050
S40V PDUN R/L 15-EX	40	37	18,5	400	60	27	48	DN.. 1506..	3,750
S50W PDUN R/L 15-EX	50	47	23,5	450	65	35	61	DN.. 1506..	6,500



Ref.	S32U PDUN R/L 15-EX	S40V PDUN R/L 15-EX	S50W PDUN R/L 15-EX	8415	1648	1638	1638	5003	-	-	-	-	-	3725	4135	3725	4135

For DNM.. 1504.. inserts

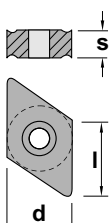

DN..

l

s

d

Negative 55° rhombic inserts.

For more information see page: A.22

Ref.	DN.. 1504..	15,50	4,76	12,70
	DN.. 1506..	15,50	6,35	12,70

DNMG-CF	DNMG-CM	DNMG-CS	
DNGP	DNMA	DNMG-CFC	DNMG-CFM
DNMG-CMC	DNMG-CMF	DNMG-CMR	DNMX



Characteristics:

Boring bar for internal turning applications equipped with square negative inserts and strong cutting edges. The lever lock ensures good rigidity and chip flow in roughing applications.







Applications:

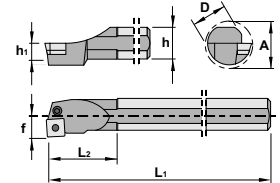





Internal boring bar for general applications, roughing, semi-finishing and finishing.





For low powered machines and small pieces choose boring bars Ref. CSKP (Page: C.07) or SSKC (Page: C.40).

Axial: -3°
Radial: -11°



PSKN 75°		Characteristics: Boring bars with steel shank.								
Ref.		D	h	h1	L1	L2	f	A	Insert size	kg
Ref.	S25T PSKN R/L 12	25	23	11,5	300	40	17	31	SNM.. 1204..	0,700
	S32U PSKN R/L 12	32	30	15,0	350	50	22	39	SNM.. 1204..	2,050
	S40V PSKN R/L 12	40	37	18,5	400	60	27	48	SNM.. 1204..	3,750
	S50W PSKN R/L 19	50	47	23,5	450	65	35	61	SNM.. 1906..	6,500
										
Ref.	S25T PSKN R/L 12	8212		1626	5025		-	-		-
	S32U PSKN R/L 12	8312		1648	5003		3512	4112		0012
	S40V PSKN R/L 12	8012		1608	5003		3512	4112		0012
	S50W PSKN R/L 19	8219		1710	5004		3519	4129		0019

A-PSKN 75°		Characteristics: Boring bars with internal coolant.								
Ref.		D	h	h1	L1	L2	f	A	Insert size	kg
Ref.	A25R PSKN R/L 12	25	23	11,5	200	40	17	31	SNM.. 1204..	0,700
	A32S PSKN R/L 12	32	30	15,0	250	50	22	39	SNM.. 1204..	1,400
	A40T PSKN R/L 12	40	37	18,5	300	60	27	48	SNM.. 1204..	2,650
										
Ref.	A25R PSKN R/L 12	8212		1626	5025		-	-		-
	A32S PSKN R/L 12	8312		1648	5003		3512	4112		0012
	A40T PSKN R/L 12	8012		1608	5003		3512	4112		0012

Ref.	SNM..				Negative square inserts.				
	SNM.. 1204..	SNM.. 1906..	l	s	d	For more information see page: A.27			
			12,70	4,76	12,70	SNMG-CR			
			19,05	6,35	19,05				
	SNMA	SNMG-CFM	SNMG-CMR	SNMM					
									

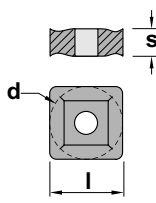

General turning
Aluminum wheel turning
Automatic lathes
Ceramic tools
Parting and grooving
Threading
Drills
Cartridges
Brazed tools
Tooling

Inserts

General turning



Characteristics:

Boring bar for internal turning applications equipped with square negative inserts and strong cutting edges. The lever lock ensures good rigidity and chip flow in roughing applications.

Applications:

Internal boring bar for general applications, roughing, semi-finishing and finishing.

For low powered machines and small pieces choose boring bars Ref. SSSC (Page: C.41).

Axial: -3°
Radial: -11°

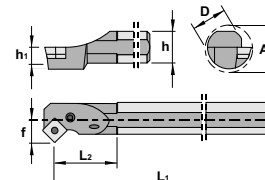

A-PSSN 45°



Characteristics:

Boring bars with internal coolant.

Ref.	D	h	h ₁	L ₁	L ₂	f	A	Insert size	Kg
A25R PSSN R/L 12	25	23	11,5	200	40	17	31	SNM.. 1204..	0,700
A32S PSSN R/L 12	32	30	15,0	250	50	22	39	SNM.. 1204..	2,050



Ref.	A25R PSSN R/L 12	A32S PSSN R/L 12	8212	8312	1626	1648	5025	5003	-	3512	-	4112	-	0012

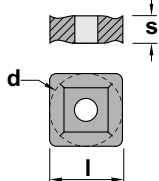

SNM..

l s d

Negative square inserts.

For more information see page: A.27

Ref.	SNM.. 1204..	12,70	4,76	12,70	SNMG-CR			
	SNMA	SNMG-CFM	SNMG-CMR	SNMM				



Characteristics:

Boring bar for internal turning applications equipped with triangular negative inserts and strong cutting edges. The lever lock ensures good rigidity and chip flow in roughing applications.

Applications:

Internal boring bar for general applications, roughing, semi-finishing and finishing.

For low powered machines and small pieces choose boring bars Ref. CTFP (Page: C.08) or STFC (Page: C.42).

Axial: -6°
Radial: -11°

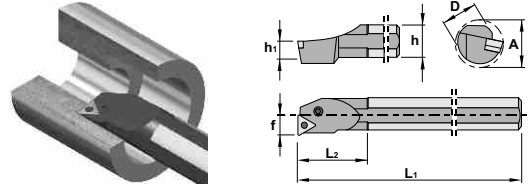

PTFN 90°		Characteristics: Boring bars with steel shank.																								
Ref.		D	h	h1	L1	L2	f	A	Insert size	Kg																
	S25T PTFN R/L 16	25	23	11,5	300	40	17	31	TNM.. 1604..	0,700																
	S32U PTFN R/L 16	32	30	15,0	350	50	22	39	TNM.. 1604..	2,050																
	S40V PTFN R/L 22	40	37	18,5	400	60	27	48	TNM.. 2204..	3,750																
	S50W PTFN R/L 22	50	47	23,5	450	65	35	61	TNM.. 2204..	6,500																
Ref.		8216	8009	8012	8012	1605	1606	1608	1608	5002	5025	5003	5003	-	-	-	3416	4109	3422	4112	3422	4112	0009	0012	0012	
	S25T PTFN R/L 16																									
	S32U PTFN R/L 16																									
	S40V PTFN R/L 22																									
	S50W PTFN R/L 22																									

A-PTFN 90°		Characteristics: Boring bars with internal coolant.														
Ref.		D	h	h1	L1	L2	f	A	Insert size	Kg						
	A25R PTFN R/L 16	25	23	11,5	200	40	17	31	TNM.. 1604..	0,700						
	A32S PTFN R/L 16	32	30	15,0	250	50	22	39	TNM.. 1604..	1,400						
	A40T PTFN R/L 22	40	37	18,5	300	60	27	48	TNM.. 2204..	2,650						
Ref.		8216	8009	8012	1605	1606	1608	5002	5025	5003	3416	4109	3422	4112	0009	0012
	A25R PTFN R/L 16															
	A32S PTFN R/L 16															
	A40T PTFN R/L 22															

	TNM..				Negative triangular inserts.		
	Ref.	l	s	d	For more information see page: A.29		
	TNM.. 1604..	16,50	4,76	9,52	TNMG-CF	TNMG-CM	TNMG-CS
	TNM.. 2204..	22,00	4,76	12,70			
	TNMA	TNMG-CFC	TNMG-CFM	TNMG-CMC	TNMG-CMF	TNMG-CMR	TNMX

General turning
Aluminium wheel turning
Automatic lathes
Ceramic tools
Parting and grooving
Threading
Drills
Cartridges
Brazed tools
Tooling

Inserts

General turning



Characteristics:

Boring bar for internal turning applications equipped with trigon negative inserts (angle 80°) and strong cutting edges.

The lever lock ensures good rigidity and chip flow in roughing applications.

Applications:

Internal boring bar for general applications, roughing, semi-finishing and finishing.

Axial: -6°
Radial: -13.5°

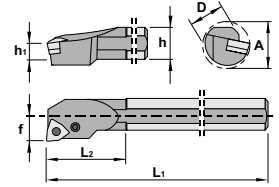

PWLN 95°

Characteristics:
 Boring bars with steel shank.

Ref.		D	h	h1	L1	L2	f	A	Insert size	Kg
S16R PWLN R/L 06	S16R PWLN R/L 06	16	15	7,5	200	24	11	20	WNM.. 0604..	0,300
	S20S PWLN R/L 06	20	18	9,0	250	36	13	27	WNM.. 0604..	0,550
	S25T PWLN R/L 06	25	23	11,5	300	40	17	31	WNM.. 0604..	0,700
S25T PWLN R/L 08	S25T PWLN R/L 08	25	23	11,5	300	40	17	31	WNM.. 0804..	0,700
S32U PWLN R/L 08	S32U PWLN R/L 08	32	30	15,0	350	50	22	39	WNM.. 0804..	2,050
S40V PWLN R/L 08	S40V PWLN R/L 08	40	37	18,5	400	60	27	48	WNM.. 0804..	3,750



Ref.							
S16R PWLN R/L 06	S16R PWLN R/L 06	8216	1605	5002	-	-	-
	S20S PWLN R/L 06	8216	1605	5002	-	-	-
	S25T PWLN R/L 06	8009	1606	5025	3007	4109	0009
S25T PWLN R/L 08	S25T PWLN R/L 08	8312	1648	5003	-	-	-
S32U PWLN R/L 08	S32U PWLN R/L 08	8012	1608	5003	3008	4112	0012
S40V PWLN R/L 08	S40V PWLN R/L 08	8012	1608	5003	3008	4112	0012

	WNM..				Negative 80° trigon inserts.		
	Ref.	l	s	d	WNMG-CF	WNMG-CM	WNMG-CS
	WNM.. 0604..	6,45	4,76	9,52			
WNM.. 0804..	8,14	4,76	12,70				
	WNMA	WNMG-CFM	WNMG-CMC	WNMG-CMF	WNMG-CMR		



Characteristics:

Boring bar for internal turning applications equipped with trigon negative inserts (angle 80°) and strong cutting edges.

The lever lock ensures good rigidity and chip flow in roughing applications.

Applications:

Internal boring bar for general applications, roughing, semi-finishing and finishing.

Axial: -6°
Radial: -13.5°

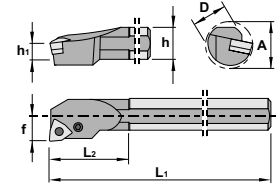

A-PWLN 95°



Characteristics:

Boring bars with internal coolant.

Ref.		D	h	h1	L1	L2	f	A	Insert size	kg
A16M PWLN R/L 06		16	15	7,5	150	24	11	20	WNM.. 0604..	0,200
A20Q PWLN R/L 06		20	18	9,0	180	36	13	27	WNM.. 0604..	0,400
A25R PWLN R/L 06		25	23	11,5	200	40	17	31	WNM.. 0604..	0,700
A32S PWLN R/L 06		32	30	15,0	250	50	22	39	WNM.. 0604..	1,400
A25R PWLN R/L 08		25	23	11,5	200	40	17	31	WNM.. 0804..	0,700
A32S PWLN R/L 08		32	30	15,0	250	50	22	39	WNM.. 0804..	1,400
A40T PWLN R/L 08		40	37	18,5	300	60	27	48	WNM.. 0804..	2,650

Ref.	A16M PWLN R/L 06	A20Q PWLN R/L 06	A25R PWLN R/L 06	A32S PWLN R/L 06	A25R PWLN R/L 08	A32S PWLN R/L 08	A40T PWLN R/L 08
	8216	8216	8009	8009	8312	8012	8012
	1605	1605	1606	1606	1648	1608	1608
	5002	5002	5025	5025	5003	5003	5003
	-	-	3007	3007	-	3008	3008
	-	-	4109	4109	-	4112	4112
	-	-	0009	0009	-	0012	0012

Ref.	WNM..				Negative 80° trigon inserts.			
	WNM.. 0604..	WNM.. 0804..	l	s	d	WNGM-CF	WNGM-CM	WNGM-CS
	6,45	8,14	4,76	4,76	9,52			
WNGM-CF	WNGM-CM	WNGM-CS	WNGM-CR	WNGM-CR	WNGM-CR	WNGM-CR	WNGM-CR	

General turning

Aluminium wheel turning

Automatic lathes

Ceramic tools

Parting and grooving

Threading

Drills

Cartridges

Brazed tools

Tooling

Inserts

General turning



Characteristics:

Multipurpose boring bar equipped with rhombic positive insert (angle 80°).
 The center screw ensures good rigidity and chip flow.

Applications:

Internal boring bar for general applications, roughing, semi-finishing and finishing.

Negative inserts boring bars Ref. MCLN-K (Page: C.12) or PCLN (Page: C.22).

Axial: 0°
Radial: -6°

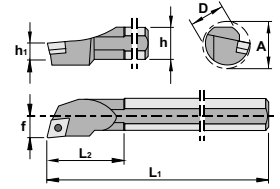

SCLC 95°

Characteristics:
 Boring bars with steel shank.

Ref.		D	h	h1	L1	L2	f	A	Insert size	Kg
S08K SCLC R/L 06	S08K SCLC R/L 06	8	7	3,5	125	16	5	11	CC.. 0602..	0,040
	S10M SCLC R/L 06	10	9	4,5	150	25	7	13	CC.. 0602..	0,060
	S12M SCLC R/L 06	12	11	5,5	150	25	9	16	CC.. 0602..	0,150
S12M SCLC R/L 09	S12M SCLC R/L 09	12	11	5,5	150	25	9	16	CC.. 09T3..	0,150
	S12Q SCLC R/L 09	12	11	5,5	180	25	9	16	CC.. 09T3..	0,150
	S16R SCLC R/L 09	16	15	7,5	200	30	11	20	CC.. 09T3..	0,300
	S20S SCLC R/L 09	20	18	9,0	250	35	13	24	CC.. 09T3..	0,550
	S25T SCLC R7L 09	25	23	11,5	300	40	17	31	CC.. 09T3..	0,550
	S20S SCLC R/L 12	20	18	9,0	250	35	13	24	CC.. 1204..	0,550
S25T SCLC R/L 12	S25T SCLC R/L 12	25	23	11,5	300	40	17	31	CC.. 1204..	0,700
	S32U SCLC R/L 12	32	30	15,0	350	50	22	39	CC.. 1204..	2,050
	S40V SCLC R/L 12	40	37	18,5	400	60	27	48	CC.. 1204..	3,750
	S50W SCLC R/L 12	50	47	23,5	450	65	35	61	CC.. 1204..	6,500
	S25T SCLC R/L 12	25	23	11,5	300	40	17	31	CC.. 1204..	0,700



Ref.					
S08K SCLC R/L 06	S08K SCLC R/L 06	1425	5507	-	-
	S10M SCLC R/L 06	1425	5507	-	-
	S12M SCLC R/L 06	1425	5507	-	-
S12M SCLC R/L 09	S12M SCLC R/L 09	1440	5515	-	-
	S12Q SCLC R/L 09	1440	5515	-	-
	S16R SCLC R/L 09	1440	5515	-	-
	S20S SCLC R/L 09	1440	5515	-	-
	S25T SCLC R7L 09	1440	5515	-	-
	S20S SCLC R/L 12	1250	5520	-	-
S25T SCLC R/L 12	S25T SCLC R/L 12	1250	5520	-	-
	S32U SCLC R/L 12	1540	5517	3614	1760
	S40V SCLC R/L 12	1540	5517	3614	1760
	S50W SCLC R/L 12	1540	5517	3614	1760
	S25T SCLC R/L 12	1250	5520	-	-

Ref.	CC..	l	s	d	Positive 7° clearance - 80° rhombic inserts.
	CC.. 0602..	6,45	2,38	6,35	
CC.. 09T3..	9,65	3,97	9,52		
CC.. 1204..	12,90	4,76	12,70		

CCGT-AL	CCGT-AP	CCMT-03	CCMW

For more information see page: A.18



Characteristics:
Boring bars with internal coolant.

A-SCLC 95°		D	h	h1	L1	L2	f	A	Insert size	
Ref.	A08F SCLC R/L 06	8	7	3,5	80	16	5	11	CC.. 0602..	0,030
	A10H SCLC R/L 06	10	9	4,5	100	25	7	13	CC.. 0602..	0,040
	A12K SCLC R/L 06	12	11	5,5	125	25	9	16	CC.. 0602..	0,100
	A16M SCLC R/L 09	16	15	7,5	150	30	11	20	CC.. 09T3..	0,200
	A20Q SCLC R/L 09	20	18	9,0	180	35	13	24	CC.. 09T3..	0,400
	A25R SCLC R/L 09	25	23	11,5	200	40	17	31	CC.. 09T3..	0,700
	A32S SCLC R/L 12	32	30	15,0	250	50	22	39	CC.. 1204..	1,400
	A40T SCLC R/L 12	40	37	18,5	300	60	27	48	CC.. 1204..	2,650

Ref.	A08F SCLC R/L 06	1425			5507		-			-
	A10H SCLC R/L 06	1425			5507		-			-
	A12K SCLC R/L 06	1425			5507		-			-
	A16M SCLC R/L 09	1440			5515		-			-
	A20Q SCLC R/L 09	1440			5515		-			-
	A25R SCLC R/L 09	1440			5515		-			-
	A32S SCLC R/L 12	1540			5517		3614		1760	
	A40T SCLC R/L 12	1540			5517		3614		1760	



Characteristics:
Boring bars with anti-vibration shank.

H-SCLC 95°		D	h	h1	L1	L2	f	A	Insert size	
Ref.	H08K SCLC R/L 06	8	7	3,5	125	16	5	11	CC.. 0602..	0,100
	H10M SCLC R/L 06	10	9	4,5	150	25	7	13	CC.. 0602..	0,200
	H12M SCLC R/L 06	12	11	5,5	150	25	9	16	CC.. 0602..	0,300
	H16R SCLC R/L 09	16	15	7,5	200	30	11	20	CC.. 09T3..	0,650

Ref.	H08K SCLC R/L 06		1425					5507		
	H10M SCLC R/L 06		1425					5507		
	H12M SCLC R/L 06		1425					5507		
	H16R SCLC R/L 09		1440					5515		



Characteristics:
Boring bars with internal coolant and anti-vibration shank.

J-SCLC 95°		D	h	h1	L1	L2	f	A	Insert size	
Ref.	J08K SCLC R/L 06	8	7	3,5	125	16	5	11	CC.. 0602..	0,080
	J10M SCLC R/L 06	10	9	4,5	150	25	7	13	CC.. 0602..	0,150
	J12M SCLC R/L 06	12	11	5,5	150	25	9	16	CC.. 0602..	0,250
	J16R SCLC R/L 09	16	15	7,5	200	30	11	20	CC.. 09T3..	0,600

Ref.	J08K SCLC R/L 06		1425					5507		
	J10M SCLC R/L 06		1425					5507		
	J12M SCLC R/L 06		1425					5507		
	J16R SCLC R/L 09		1440					5515		

Inserts

General turning



Characteristics:

Multipurpose internal and external boring bar equipped with rhombic positive insert (angle 80°). The center screw ensures good rigidity and chip flow.

Applications:

Internal boring bar for general applications, roughing, semi-finishing and finishing.

Axial: 0°
Radial: -9°

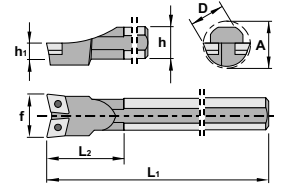

SCLCN 95°

Characteristics:
 Boring bars with steel shank.

Ref.		D	h	h1	L1	L2	f	A	Insert size	Kg
S12M SCLC N 06	S12M SCLC N 06	12	11	5,5	150	25	18	20	CC.. 0602..	0,150
	S16R SCLC N 06	16	15	7,5	200	30	22	25	CC.. 0602..	0,300
	S20S SCLC N 06	20	18	9,0	250	35	26	30	CC.. 0602..	0,550
S25T SCLC N 09	S25T SCLC N 09	25	23	11,5	300	40	34	40	CC.. 09T3..	0,700
S32U SCLC N 12	S32U SCLC N 12	32	30	15,0	350	50	44	50	CC.. 1204..	2,050
S40V SCLC N 12	S40V SCLC N 12	40	37	18,5	400	60	54	60	CC.. 1204..	3,750
S50W SCLC N 12	S50W SCLC N 12	50	47	23,5	450	65	62	68	CC.. 1204..	6,500



Ref.	S12M SCLC N 06	1425	5507	-	-
	S16R SCLC N 06	1225	5507	-	-
	S20S SCLC N 06	1225	5507	-	-
	S25T SCLC N 09	1440	5515	-	-
	S32U SCLC N 12	1540	5517	3614	1760
	S40V SCLC N 12	1540	5517	3614	1760
	S50W SCLC N 12	1540	5517	3614	1760

	CC..				Positive 7° clearance - 80° rhombic inserts.
	Ref.	l	s	d	
	CC.. 0602..	6,45	2,38	6,35	For more information see page: A.18
	CC.. 09T3..	9,65	3,97	9,52	
	CC.. 1204..	12,90	4,76	12,70	
	CCGT-AL	CCGT-AP	CCMT-03	CCMW	



Characteristics:

Multipurpose profiling boring bar equipped with rhombic positive insert (angle 55°).
The center screw ensures good rigidity and chip flow.

Applications:

Profiling boring bar for general applications, roughing, semi-finishing and finishing.

Axial: 0°
Radial: -6°

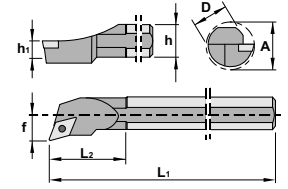

SDQC 107°30'

Characteristics:

Boring bars with steel shank.

Ref.		D	h	h1	L1	L2	f	A	Insert size	kg
S10M SDQC R/L 07		10	9	4,5	150	25	7	13	DC.. 0702..	0,060
S12M SDQC R/L 07		12	11	5,5	150	25	9	16	DC.. 0702..	0,150
S16R SDQC R/L 07		16	15	7,5	200	30	11	20	DC.. 0702..	0,300
S20S SDQC R/L 07		20	18	9,0	250	35	13	24	DC.. 11T3..	0,550
S20S SDQC R/L 11		20	18	9,0	250	35	13	24	DC.. 11T3..	0,550
S25T SDQC R/L 11		25	23	11,5	300	40	17	31	DC.. 11T3..	0,700
S32U SDQC R/L 11		32	30	15,0	350	50	22	39	DC.. 11T3..	2,050
S40V SDQC R/L 11		40	37	18,5	400	60	27	48	DC.. 11T3..	3,750



Ref.	S10M SDQC R/L 07	1425			5507		-		-	
	S12M SDQC R/L 07	1225			5507		-		-	
	S16R SDQC R/L 07	1225			5507		-		-	
	S20S SDQC R/L 07	1225			5507		-		-	
	S20S SDQC R/L 11	1240			5515		-		-	
	S25T SDQC R/L 11	1240			5515		-		-	
	S32U SDQC R/L 11	1335			5516		3714		1750	
	S40V SDQC R/L 11	1335			5516		3714		1750	

A-SDQC 107°30'



Characteristics:

Boring bars with internal coolant.

Ref.		D	h	h1	L1	L2	f	A	Insert size	kg
A12K SDQC R/L 07		12	11	5,5	125	25	9	16	DC.. 0702..	0,100
A16M SDQC R/L 07		16	15	7,5	150	30	11	20	DC.. 0702..	0,200
A20Q SDQC R/L 11		20	18	9,0	180	35	13	24	DC.. 11T3..	0,400
A25R SDQC R/L 11		25	23	11,5	200	40	17	31	DC.. 11T3..	0,700
A32S SDQC R/L 11		32	30	15,0	250	50	22	39	DC.. 11T3..	1,400
A40T SDQC R/L 11		40	37	18,5	300	60	27	48	DC.. 11T3..	2,650



Ref.	A12K SDQC R/L 07	1225			5507		-		-	
	A16M SDQC R/L 07	1225			5507		-		-	
	A20Q SDQC R/L 11	1240			5515		-		-	
	A25R SDQC R/L 11	1240			5515		-		-	
	A32S SDQC R/L 11	1335			5516		3714		1750	
	A40T SDQC R/L 11	1335			5516		3714		1750	

Ref.	DC..		l	s	d	Positive 7° clearance - 55° rhombic inserts.
	DC.. 0702..		7,75	2,38	6,35	
DC.. 11T3..		11,60	3,97	9,52		

DCGT-AL	DCGT-AP	DCMT-03	DCMW

For more information see page: A.21

Inserts

General turning



Characteristics:

Multipurpose profiling boring bar equipped with rhombic positive insert (angle 55°). The center screw ensures good rigidity and chip flow.

Applications:

Profiling boring bar for general applications, roughing, semi-finishing and finishing.

Negative inserts boring bars Ref. MDUN-K (Page: C.13) or PDUN (Page: C.23).

Axial: 0°
Radial: -6°

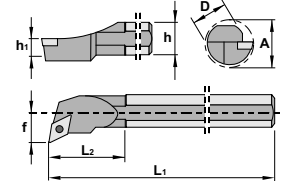

SDUC 93°

Characteristics:
 Boring bars with steel shank.

Ref.		D	h	h1	L1	L2	f	A	Insert size	Kg
S10M SDUC R/L 07	S10M SDUC R/L 07	10	9	4,5	150	25	7	13	DC.. 0702..	0,060
	S12M SDUC R/L 07	12	11	5,5	150	25	9	16	DC.. 0702..	0,150
	S12Q SDUC R/L 07	12	11	5,5	180	25	9	16	DC.. 0702..	0,150
	S16R SDUC R/L 07	16	15	7,5	200	30	11	20	DC.. 0702..	0,300
	S20S SDUC R/L 07	20	18	9,0	250	35	13	24	DC.. 0702..	0,550
S20S SDUC R/L 11	S20S SDUC R/L 11	20	18	9,0	250	35	13	24	DC.. 11T3..	0,550
	S25T SDUC R/L 11	25	23	11,5	300	40	17	31	DC.. 11T3..	0,700
	S32U SDUC R/L 11	32	30	15,0	350	50	22	39	DC.. 11T3..	2,050
	S40V SDUC R/L 11	40	37	18,5	400	60	27	48	DC.. 11T3..	3,750

Ref.					
S10M SDUC R/L 07	S10M SDUC R/L 07	1425	5507	-	
	S12M SDUC R/L 07	1225	5507	-	
	S12Q SDUC R/L 07	1225	5507	-	
	S16R SDUC R/L 07	1225	5507	-	
	S20S SDUC R/L 07	1225	5507	-	
S20S SDUC R/L 11	S20S SDUC R/L 11	1240	5515	-	
	S25T SDUC R/L 11	1240	5515	-	
	S32U SDUC R/L 11	1335	5516	3714	
	S40V SDUC R/L 11	S40V SDUC R/L 11	1335	5516	3714

	DC..				Positive 7° clearance - 55° rhombic inserts. For more information see page: A.21
	Ref.	l	s	d	
	DC.. 0702..	7,75	2,38	6,35	
DC.. 11T3..	11,60	3,97	9,52		
DCGT-AL	DCGT-AP	DCMT-03	DCMW		



Characteristics:
Boring bars with internal coolant.

A-SDUC 93°		D	h	h1	L1	L2	f	A	Insert size	
Ref.	A12K SDUC R/L 07	12	11	5,5	125	25	9	16	DC.. 0702..	0,100
	A16M SDUC R/L 07	16	15	7,5	150	30	11	20	DC.. 0702..	0,200
Ref.	A20Q SDUC R/L 11	20	18	9,0	180	35	13	24	DC.. 11T3..	0,400
	A25R SDUC R/L 11	25	23	11,5	200	40	17	31	DC.. 11T3..	0,700
	A32S SDUC R/L 11	32	30	15,0	250	50	22	39	DC.. 11T3..	1,400
	A40T SDUC R/L 11	40	37	18,5	300	60	27	48	DC.. 11T3..	2,650
Ref.	A12K SDUC R/L 07	1225			5507			-	-	-
	A16M SDUC R/L 07	1225			5507			-	-	-
	A20Q SDUC R/L 11	1240			5515			-	-	-
	A25R SDUC R/L 11	1240			5515			-	-	-
	A32S SDUC R/L 11	1335			5516			3714	1750	-
	A40T SDUC R/L 11	1335			5516			3714	1750	-



Characteristics:
Boring bars with anti-vibration shank.

H-SDUC 93°		D	h	h1	L1	L2	f	A	Insert size	
Ref.	H10M SDUC R/L 07	10	9	4,5	150	25	7	13	DC.. 0702..	0,200
	H12M SDUC R/L 07	12	11	5,5	150	25	9	16	DC.. 0702..	0,300
	H16R SDUC R/L 07	16	15	7,5	200	30	11	20	DC.. 0702..	0,650
Ref.	H10M SDUC R/L 07	1425			5507			-	-	-
	H12M SDUC R/L 07	1225			5507			-	-	-
	H16R SDUC R/L 07	1225			5507			-	-	-



Characteristics:
Boring bars with internal coolant and anti-vibration shank.

J-SDUC 93°		D	h	h1	L1	L2	f	A	Insert size	
Ref.	J10M SDUC R/L 07	10	9	4,5	150	25	7	13	DC.. 0702..	0,150
	J12M SDUC R/L 07	12	11	5,5	150	25	9	16	DC.. 0702..	0,250
	J16R SDUC R/L 07	16	15	7,5	200	30	11	20	DC.. 0702..	0,600
Ref.	J10M SDUC R/L 07	1425			5507			-	-	-
	J12M SDUC R/L 07	1225			5507			-	-	-
	J16R SDUC R/L 07	1225			5507			-	-	-

General turning

Aluminium
wheel turning

Automatic lathes

Ceramic tools

Parting and
grooving

Threading

Drills

Cartridges

Brazed tools

Tooling

Inserts

General turning



Characteristics:

Backwards Multipurpose profiling boring bar equipped with rhombic positive insert (angle 55°). The center screw ensures good rigidity and chip flow.

Applications:

Backwards profiling boring bar for general applications, roughing, semi-finishing and finishing.

Negative inserts boring bars Ref. PDUN-EX (Page: C.24).

Axial: 0°
Radial: -6°

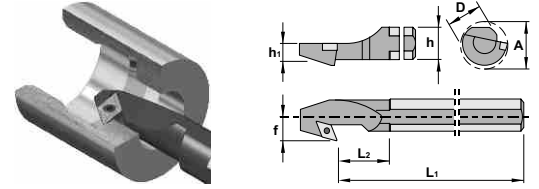

SDUC 93°-EX

Characteristics:
 Boring bars with steel shank.

Ref.		D	h	h1	L1	L2	f	A	Insert size	Kg
S12M SDUC R/L 07-EX	S12M SDUC R/L 07-EX	12	11	5,5	150	25	9	16	DC.. 0702..	0,150
	S16R SDUC R/L 07-EX	16	15	7,5	200	30	11	20	DC.. 0702..	0,300
	S20S SDUC R/L 07-EX	20	18	9,0	250	35	13	24	DC.. 0702..	0,550
S20S SDUC R/L 11-EX	S20S SDUC R/L 11-EX	20	18	9,0	250	35	13	24	DC.. 11T3..	0,550
	S25T SDUC R/L 11-EX	25	23	11,5	300	40	17	31	DC.. 11T3..	0,700
	S32U SDUC R/L 11-EX	32	30	15,0	350	50	22	39	DC.. 11T3..	2,050
	S40V SDUC R/L 11-EX	40	37	18,5	400	60	27	48	DC.. 11T3..	3,750

Ref.								
S12M SDUC R/L 07-EX	S12M SDUC R/L 07-EX	1225	5507	-	-	-	-	-
	S16R SDUC R/L 07-EX	1225	5507	-	-	-	-	-
	S20S SDUC R/L 07-EX	1225	5507	-	-	-	-	-
S20S SDUC R/L 11-EX	S20S SDUC R/L 11-EX	1440	5515	-	-	-	-	-
	S25T SDUC R/L 11-EX	1240	5515	-	-	-	-	-
	S32U SDUC R/L 11-EX	1335	5516	3714	1750	-	-	-
	S40V SDUC R/L 11-EX	1335	5516	3714	1750	-	-	-

	DC..				Positive 7° clearance - 55° rhombic inserts. For more information see page: A.21
	Ref.	l	s	d	
	DC.. 0702..	7,75	2,38	6,35	
DC.. 11T3..	11,60	3,97	9,52		
DCGT-AL	DCGT-AP	DCMT-03	DCMW		



Characteristics:

Backwards Multipurpose profiling boring bar equipped with rhombic positive insert (angle 55°). The center screw ensures good rigidity and chip flow.

Applications:

Backwards profiling boring bar for general applications, roughing, semi-finishing and finishing.

Negative inserts boring bars Ref. PDUN-EX (Page: C.24).

Axial: 0°
Radial: -6°

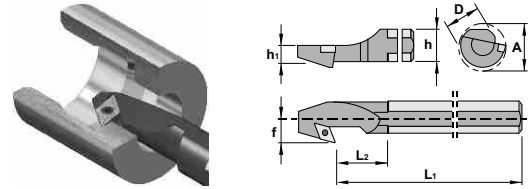

A-SDUC 93°-EX



Characteristics:

Boring bars with internal coolant.

Ref.		D	h	h1	L1	L2	f	A	Insert size	kg
A12K SDUC R/L 07-EX	A12K SDUC R/L 07-EX	12	11	5,5	125	25	9	16	DC.. 0702..	0,100
	A16M SDUC R/L 07-EX	16	15	7,5	150	30	11	20	DC.. 0702..	0,200
A20Q SDUC R7L 11-EX	A20Q SDUC R7L 11-EX	20	18	9,0	180	35	13	24	DC.. 11T3..	0,400
	A25R SDUC R/L 11-EX	25	23	11,5	200	40	17	31	DC.. 11T3..	0,700

Ref.		1225	5507
A12K SDUC R/L 07-EX	A12K SDUC R/L 07-EX	1225	5507
	A16M SDUC R/L 07-EX	1225	5507
A20Q SDUC R7L 11-EX	A20Q SDUC R7L 11-EX	1440	5515
	A25R SDUC R/L 11-EX	1240	5515

Ref.	DC..	l	s	d	Positive 7° clearance - 55° rhombic inserts.
	DC.. 0702..	7,75	2,38	6,35	
DC.. 11T3..	11,60	3,97	9,52		
DCGT-AL	DCGT-AP	DCMT-03	DCMW		

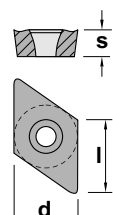

For more information see page: A.21

General turning
Aluminum wheel turning
Automatic lathes
Ceramic tools
Parting and grooving
Threading
Drills
Cartridges
Brazed tools
Tooling

Inserts

General turning



Characteristics:

Multipurpose boring bar equipped with rhombic positive insert (angle 75°).
 The center screw ensures good rigidity and chip flow.

Applications:

Internal boring bar for general applications, roughing, semi-finishing and finishing.

Axial: 0°
Radial: -7°

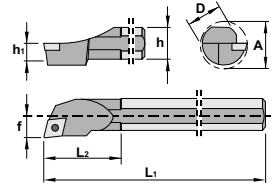

SELC 97°30'

Characteristics:
 Boring bars with steel shank.

Ref.		D	h	h1	L1	L2	f	A	Insert size	Kg
S08K SELC R/L 06	S08K SELC R/L 06	8	7	3,5	125	16	5	11	ECMT 0602..	0,040
	S10M SELC R/L 06	10	9	4,5	150	25	7	13	ECMT 0602..	0,060
S12M SELC R/L 08	S12M SELC R/L 08	12	11	5,5	150	25	9	16	ECMT 0803..	0,150
S16R SELC R/L 08	S16R SELC R/L 08	16	15	7,5	200	30	11	20	ECMT 0803..	0,300
S20S SELC R/L 08	S20S SELC R/L 08	20	18	9,0	250	35	13	24	ECMT 0803..	0,550



Ref.	S08K SELC R/L 06	1425	5507
	S10M SELC R/L 06	1425	5507
	S12M SELC R/L 08	1430	5508
	S16R SELC R/L 08	1430	5508
	S20S SELC R/L 08	1230	5508

	ECMT				Positive 7° clearance - 75° Rhombic inserts
	Ref.	l	s	d	
	ECMT 0602..	6,57	2,38	6,35	For more information see page: A.24
	ECMT 0803..	8,20	3,18	7,93	
	ECMT				



Characteristics:

Multipurpose boring bar equipped with rhombic positive insert (angle 75°).
The center screw ensures good rigidity and chip flow.

Applications:

Internal boring bar for general applications, roughing, semi-finishing and finishing.

Axial: 0°
Radial: -5°

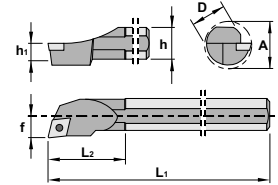

SELP 97°30'

Characteristics:
Boring bars with steel shank.

Ref.	D	h	h1	L1	L2	f	A	Insert size	
S08K SELP R/L 04	8	7	3,5	125	16	5	11	EPM.. 0402..	0,040
S10M SELP R/L 08	10	9	4,5	150	25	7	13	EPM.. 0803..	0,060
S12M SELP R/L 08	12	11	5,5	150	25	9	16	EPM.. 0803..	0,150
S16R SELP R/L 08	16	15	7,5	200	30	11	20	EPM.. 0803..	0,300

Ref.		
S08K SELP R/L 04	1220	5506
S10M SELP R/L 08	1140	5515
S12M SELP R/L 08	1140	5515
S16R SELP R/L 08	1140	5515

Ref.	EPM..			Positive 11° clearance - 75° Rhombic inserts
	l	s	d	
EPM.. 0402..	4,92	2,38	4,76	For more information see page: A.24
EPM.. 0803..	8,28	3,00	8,00	
	EPMT	EPMW	EPMX	

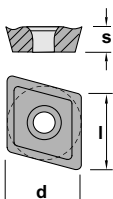

General turning

Aluminium wheel turning

Automatic lathes

Ceramic tools

Parting and grooving

Threading

Drills

Cartridges

Brazed tools

Tooling

Inserts

General turning



Characteristics:

Multipurpose boring bar equipped with square positive insert. The center screw ensures good rigidity and chip flow.

Applications:

Internal boring bar for general applications, roughing, semi-finishing and finishing.

Negative inserts boring bars Ref. MSKN-K (Page: C.14) or PSKN (Page: C.25).

Axial: 0°
Radial: -8°

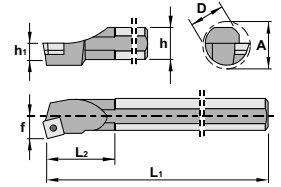

SSKC 75°

Characteristics:
 Boring bars with steel shank.

Ref.		D	h	h1	L1	L2	f	A	Insert size	Kg
S16R SSKC R/L 09	S16R SSKC R/L 09	16	15	7,5	200	30	11	20	SC.. 09T3..	0,300
	S20S SSKC R/L 09	20	18	9,0	250	35	13	24	SC.. 09T3..	0,550
	S25T SSKC R/L 09	25	23	11,5	300	40	17	31	SC.. 09T3..	0,700
S32U SSKC R/L 12	S32U SSKC R/L 12	32	30	15,0	350	50	22	39	SC.. 1204..	2,050
	S40V SSKC R/L 12	40	37	18,5	400	60	27	48	SC.. 1204..	3,750
	S50W SSKC R/L 12	50	47	23,5	450	65	35	61	SC.. 1204..	6,500



Ref.	S16R SSKC R/L 09	1440	5515	-	-
	S20S SSKC R/L 09	1240	5515	-	-
	S25T SSKC R/L 09	1240	5515	-	-
	S32U SSKC R/L 12	1540	5517	3514	1760
	S40V SSKC R/L 12	1540	5517	3514	1760
	S50W SSKC R/L 12	1540	5517	3514	1760

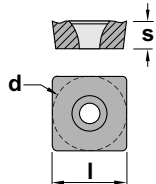

SC..

l

s

d

Positive 7° clearance - Square inserts

Ref.	SC.. 09T3..	9,52	3,97	9,52
	SC.. 1204..	12,70	4,76	12,70

For more information see page: A.26

SCGT-AL

SCMT-03

SCMT-39

SCMW





Characteristics:

Multipurpose boring bar equipped with square positive insert. The center screw ensures good rigidity and chip flow.

Applications:

Internal boring bar for general applications, roughing, semi-finishing and finishing.

Negative inserts boring bars Ref. PSSN (Page: C.26).

Axial: 0°
Radial: -8°

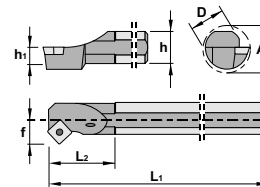

A-SSSC 45°



Characteristics:

Boring bars with internal coolant.

Ref.		D	h	h1	L1	L2	f	A	Insert size	Kg
A16M SSSC R/L 09		16	15	7,5	150	30	11	20	SC.. 09T3..	0,300
A20Q SSSC R/L 09		20	18	9,0	180	35	13	24	SC.. 09T3..	0,550
A25R SSSC R/L 09		25	23	11,5	200	40	17	31	SC.. 09T3..	0,700

General turning

Aluminium wheel turning

Automatic lathes

Ceramic tools

Parting and grooving

Threading

Drills

Cartridges

Brazed tools

Tooling

Ref.			
A16M SSSC R/L 09		1440	5515
A20Q SSSC R/L 09		1240	5515
A25R SSSC R/L 09		1240	5515

	SC..				Positive 7° clearance - Square inserts
	Ref.	l	s	d	
	SC.. 09T3..	9,52	3,97	9,52	For more information see page: A.26
	SCGT-AL	SCMT-03	SCMT-39	SCMW	

Inserts

General turning



Characteristics:

Multipurpose boring bar equipped with triangular positive insert. The center screw ensures good rigidity and chip flow.

Applications:

Internal boring bar for general applications, roughing, semi-finishing and finishing.

Negative inserts boring bars Ref. MTFN (Page: C.15) or MTFN-K (Page: C.16) or PTFN (Page: C.27).

Axial: 0°
Radial: -6°

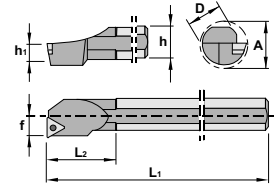

STFC 90°

Characteristics:
 Boring bars with steel shank.

Ref.		D	h	h1	L1	L2	f	A	Insert size	Kg
S10M STFC R/L 09		10	9	4,5	150	25	7	13	TC.. 0902..	0,060
	S12M STFC R/L 09	12	11	5,5	150	25	9	16	TC.. 0902..	0,150
S12M STFC R/L 11		12	11	5,5	150	25	9	16	TC.. 1102..	0,150
S12Q STFC R/L 11		12	11	5,5	180	25	9	16	TC.. 1102..	0,050
S16R STFC R/L 11		16	15	7,5	200	30	11	20	TC.. 1102..	0,300
S20S STFC R/L 11		20	18	9,0	250	35	13	24	TC.. 1102..	0,550
S20S STFC R/L 16		20	18	9,0	250	35	13	24	TC.. 16T3..	0,550
S25T STFC R/L 16		25	23	11,5	300	40	17	31	TC.. 16T3..	0,700
S32U STFC R/L 16		32	30	15,0	350	50	22	39	TC.. 16T3..	2,050
S40V STFC R/L 16		40	37	18,5	400	60	27	48	TC.. 16T3..	3,750

Ref.				
S10M STFC R/L 09	1222		5506	-
S12M STFC R/L 09	1222		5506	-
S12M STFC R/L 11	1225		5507	-
S12Q STFC R/L 11	1225		5507	-
S16R STFC R/L 11	1225		5507	-
S20S STFC R/L 11	1225		5507	-
S20S STFC R/L 16	1240		5515	-
S25T STFC R/L 16	1240		5515	-
S32U STFC R/L 16	1335		5516	3414
S40V STFC R/L 16	1335		5516	3414

Ref.	TC..		l	s	d	Positive 7° clearance - Triangular inserts.
	TC.. 0902..		9,62	2,38	5,55	
TC.. 1102..		11,00	2,38	6,35		
TC.. 16T3..		16,50	3,97	9,52		

TCGT-AL	TCMT-03	TCMW			

For more information see page: A.28



Characteristics:
Boring bars with internal coolant.

A-STFC 90°		D	h	h1	L1	L2	f	A	Insert size	Kg	
Ref.	A10H STFC R/L 09	10	9	4,5	100	25	7	13	TC.. 0902..	0,040	
	A12K STFC R/L 11	12	11	5,5	125	25	9	16	TC.. 1102..	0,100	
	A16M STFC R/L 11	16	15	7,5	150	30	11	20	TC.. 1102..	0,200	
	A20Q STFC R/L 11	20	18	9,0	180	35	13	24	TC.. 1102..	0,400	
	A25R STFC R/L 16	25	23	11,5	200	40	17	31	TC.. 16T3..	0,700	
	A32S STFC R/L 16	32	30	15,0	250	50	22	39	TC.. 16T3..	1,400	
	A40T STFC R/L 16	40	37	18,5	300	60	27	48	TC.. 16T3..	2,650	
Ref.	A10H STFC R/L 09	1222			5506			-	-		
	A12K STFC R/L 11	1225			5507			-	-		
	A16M STFC R/L 11	1225			5507			-	-		
	A20Q STFC R/L 11	1225			5507			-	-		
	A25R STFC R/L 16	1240			5515			-	-		
	A32S STFC R/L 16	1335			5516			3414	1750		
	A40T STFC R/L 16	1335			5516			3414	1750		



Characteristics:
Boring bars with anti-vibration shank.

H-STFC 90°		D	h	h1	L1	L2	f	A	Insert size	Kg	
Ref.	H10M STFC R/L 09	10	9	4,5	150	25	7	13	TC.. 0902..	0,200	
	H12M STFC R/L 11	12	11	5,5	150	25	9	16	TC.. 1102..	0,300	
	H16R STFC R/L 11	16	15	7,5	200	30	11	20	TC.. 1102..	0,650	
Ref.	H10M STFC R/L 09	1222			5506						
	H12M STFC R/L 11	1225			5507						
	H16R STFC R/L 11	1440			5515						



Characteristics:
Boring bars with internal coolant and anti-vibration shank.

J-STFC 90°		D	h	h1	L1	L2	f	A	Insert size	Kg	
Ref.	J10M STFC R/L 09	10	9	4,5	150	25	7	13	TC.. 0902..	0,150	
	J12M STFC R/L 11	12	11	5,5	150	25	9	16	TC.. 1102..	0,250	
	J16R STFC R/L 11	16	15	7,5	200	30	11	20	TC.. 1102..	0,600	
Ref.	J10M STFC R/L 09	1222			5506						
	J12M STFC R/L 11	1225			5507						
	J16R STFC R/L 11	1440			5515						

General turning

Aluminium
wheel turning

Automatic lathes

Ceramic tools

Parting and
grooving

Threading

Drills

Cartridges

Brazed tools

Tooling

Inserts

General turning



Characteristics:

Multipurpose boring bar equipped with triangular positive insert. The center screw ensures good rigidity and chip flow.

Applications:

Internal boring bar for general applications, roughing, semi-finishing and finishing.

Negative inserts boring bars Ref. MTUN (Page: C.17).

Axial: 0°
Radial: -4°

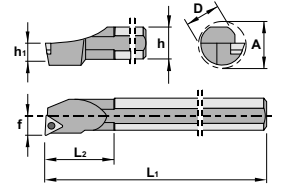

STUC 93°

Characteristics:
 Boring bars with steel shank.

Ref.	D	h	h1	L1	L2	f	A	Insert size	
S12M STUC R/L 11	12	11	5,5	150	25	9	16	TC.. 1102..	0,150
S16R STUC R/L 16	16	15	7,5	200	30	11	20	TC.. 16T3..	0,300
S20S STUC R/L 16	20	18	9,0	250	35	13	24	TC.. 16T3..	0,550
S25T STUC R/L 16	25	23	11,5	300	40	17	31	TC.. 16T3..	0,700
S32U STUC R/L 16	32	30	15,0	350	50	22	39	TC.. 16T3..	2,050



Ref.	S12M STUC R/L 11	S16R STUC R/L 16	S20S STUC R/L 16	S25T STUC R/L 16	S32U STUC R/L 16
	1225	1240	1240	1240	1335
		5515	5515	5515	5516
					3414
					1750

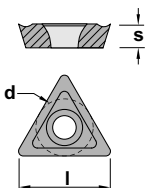

TC..

l

s

d

Positive 7° clearance - Triangular inserts.

Ref.	TC.. 1102..	TC.. 16T3..
	11,00	16,50
	2,38	3,97
	6,35	9,52

For more information see page: A.28

TCGT-AL

TCMT-03

TCMW





Characteristics:

Multipurpose profiling boring bar equipped with rhombic positive insert (angle 35°). The center screw ensures good rigidity and chip flow.

Applications:

Profiling boring bar for general applications, roughing, semi-finishing and finishing.

Axial: 0°
Radial: -6°

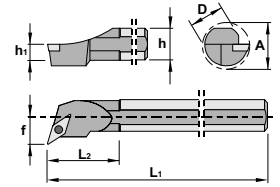

SVQC 107°30'		Characteristics: Boring bars with steel shank.								
Ref.		D	h	h1	L1	L2	f	A	Insert size	
S16R SVQC R/L 11	S16R SVQC R/L 11	16	15	7,5	200	30	11	20	VC.. 1103..	0,300
	S20S SVQC R/L 11	20	18	9,0	250	35	13	24	VC.. 1103..	0,550
S16R SVQC R/L 13	S16R SVQC R/L 13	16	15	7,5	200	30	11	20	VC.. 1303..	0,300
	S20S SVQC R/L 13	20	18	9,0	250	35	13	24	VC.. 1303..	0,550
S25T SVQC R/L 16	S25T SVQC R/L 16	25	23	11,5	300	40	17	31	VC.. 1604..	0,700

Ref.	S16R SVQC R/L 11	1225	5507	-	-	-	-	-	-	-
	S20S SVQC R/L 11	1225	5507	-	-	-	-	-	-	-
S16R SVQC R/L 13	S16R SVQC R/L 13	1230	5508	-	-	-	-	-	-	-
	S20S SVQC R/L 13	1230	5508	-	-	-	-	-	-	-
S25T SVQC R/L 16	S25T SVQC R/L 16	1335	5516	3718	1750	-	-	-	-	-

A-SVQC 107°30'		Characteristics: Boring bars with internal coolant.								
Ref.		D	h	h1	L1	L2	f	A	Insert size	
A16M SVQC R/L 11	A16M SVQC R/L 11	16	15	7,5	150	30	11	20	VC.. 1103..	0,200
	A20Q SVQC R/L 11	20	18	9,0	180	35	13	24	VC.. 1103..	0,400
A25R SVQC R/L 16	A25R SVQC R/L 16	25	23	11,5	200	40	17	31	VC.. 1604..	0,700
A32S SVQC R/L 16	A32S SVQC R/L 16	32	30	15,0	250	50	22	39	VC.. 1604..	1,400
A40T SVQC R/L 16	A40T SVQC R/L 16	40	37	18,5	300	60	27	48	VC.. 1604..	2,650

Ref.	A16M SVQC R/L 11	1225	5507	-	-	-	-	-	-	-
	A20Q SVQC R/L 11	1225	5507	-	-	-	-	-	-	-
A25R SVQC R/L 16	A25R SVQC R/L 16	1335	5516	3718	1750	-	-	-	-	-
A32S SVQC R/L 16	A32S SVQC R/L 16	1335	5516	3718	1750	-	-	-	-	-
A40T SVQC R/L 16	A40T SVQC R/L 16	1335	5516	3718	1750	-	-	-	-	-

	VC..				Positive 7° clearance - 35° Rhombic inserts.
	Ref.	l	s	d	
	VC.. 1103..	11,00	3,18	6,35	For more information see page: A.32
	VC.. 1303..	13,00	3,18	8,00	
	VC.. 1604..	16,50	4,76	9,52	
	VCGT-AL	VCGT-AP	VCMT-03		

Inserts

General turning



Characteristics:

Multipurpose profiling boring bar equipped with rhombic positive insert (angle 35°). The center screw ensures good rigidity and chip flow.

Applications:

Profiling boring bar for general applications, roughing, semi-finishing and finishing.

Negative inserts boring bars Ref. MVUN-K (Page: C.18).

Axial: 0°
Radial: -5°

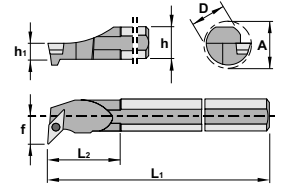

SVUB 93°

Characteristics:
 Boring bars with steel shank.

Ref.		D	h	h ₁	L ₁	L ₂	f	A	Insert size	Kg
S25T SVUB R/L 16		25	23	11,5	300	40	17	31	VBMT 1604..	0,700
S32U SVUB R/L 16		32	30	15,0	350	50	22	39	VBMT 1604..	2,050
S40V SVUB R/L 16		40	37	18,5	400	60	27	48	VBMT 1604..	3,750



Ref.	S25T SVUB R/L 16	1335	5516	3718	1750
	S32U SVUB R/L 16	1335	5516	3718	1750
	S40V SVUB R/L 16	1335	5516	3718	1750

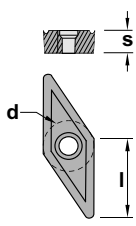

VBMT

l s d

Ref. **VBMT 1604..** 16,50 4,76 9,52

Positive 5° clearance - 35° rhombic inserts.

For more information see page: A.32

VBMT





Characteristics:

Multipurpose profiling boring bar equipped with rhombic positive insert (angle 35°).
The center screw ensures good rigidity and chip flow.

Applications:

Profiling boring bar for general applications, roughing, semi-finishing and finishing.

Negative inserts boring bars Ref. MVUN-K (Page: C.18).

Axial: 0°
Radial: -5°

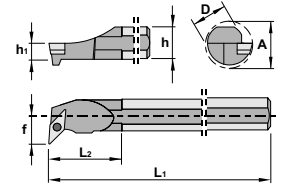

SVUC 93°		Characteristics: Boring bars with steel shank.									
Ref.		D	h	h1	L1	L2	f	A	Insert size		
	S16R SVUC R/L 11	16	15	7,5	200	30	11	20	VC.. 1103..	0,300	
	S20S SVUC R/L 11	20	18	9,0	250	35	13	24	VC.. 1103..	0,550	
	S25T SVUC R/L 16	25	23	11,5	300	40	17	31	VC.. 1604..	0,700	
	S32U SVUC R/L 16	32	30	15,0	350	50	22	39	VC.. 1604..	2,050	
	S40V SVUC R/L 16	40	37	18,5	400	60	27	48	VC.. 1604..	3,750	
	S16R SVUC R/L 11				1225				5507	-	-
	S20S SVUC R/L 11				1225				5507	-	-
	S25T SVUC R/L 16				1335				5516	3718	1750
	S32U SVUC R/L 16				1335				5516	3718	1750
	S40V SVUC R/L 16				1335				5516	3718	1750

A-SVUC 93°		Characteristics: Boring bars with internal coolant.									
Ref.		D	h	h1	L1	L2	f	A	Insert size		
	A16M SVUC R/L 11	16	15	7,5	150	30	11	20	VC.. 1103..	0,200	
	A20Q SVUC R/L 11	20	18	9,0	180	35	13	24	VC.. 1103..	0,400	
	A25R SVUC R/L 16	25	23	11,5	200	40	17	31	VC.. 1604..	0,700	
	A32S SVUC R/L 16	32	30	15,0	250	50	22	39	VC.. 1604..	1,400	
	A40T SVUC R/L 16	40	37	18,5	300	60	27	48	VC.. 1604..	2,650	
	A16M SVUC R/L 11				1225				5507	-	-
	A20Q SVUC R/L 11				1225				5507	-	-
	A25R SVUC R/L 16				1335				5516	3718	1750
	A32S SVUC R/L 16				1335				5516	3718	1750
	A40T SVUC R/L 16				1335				5516	3718	1750

	VC..				Positive 7° clearance - 35° Rhombic inserts.
	Ref.	VC.. 1103..	VC.. 1604..		
	l	s	d		
	Ref.	VC.. 1103..	11,00	3,18	6,35
		VC.. 1604..	16,50	4,76	9,52
	VCGT-AL	VCGT-AP	VCMT-03		

For more information see page: A.32

Inserts

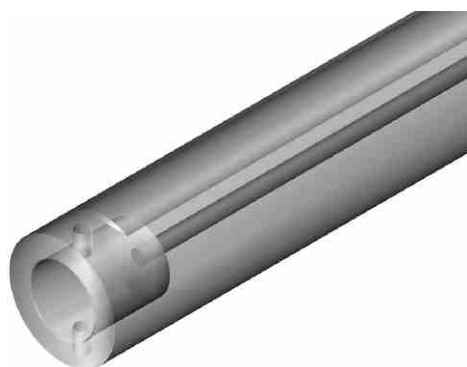

General turning

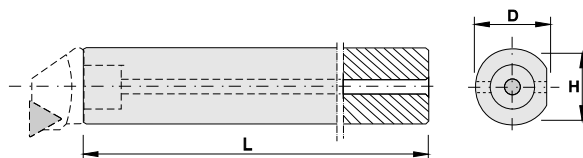

Characteristics:
 Anti-vibration shank with internal coolant

Max. cutting depth: 5 x Diameter



JX				D	L	H	
Ref.	J20X			20	225	19	1,100
	J25X			25	270	24	2,100
	J32X			32	320	31	4,150
	J40X			40	370	38	3,650
	J50X			50	510	48	8,150
	J60X			60	610	58	13,850

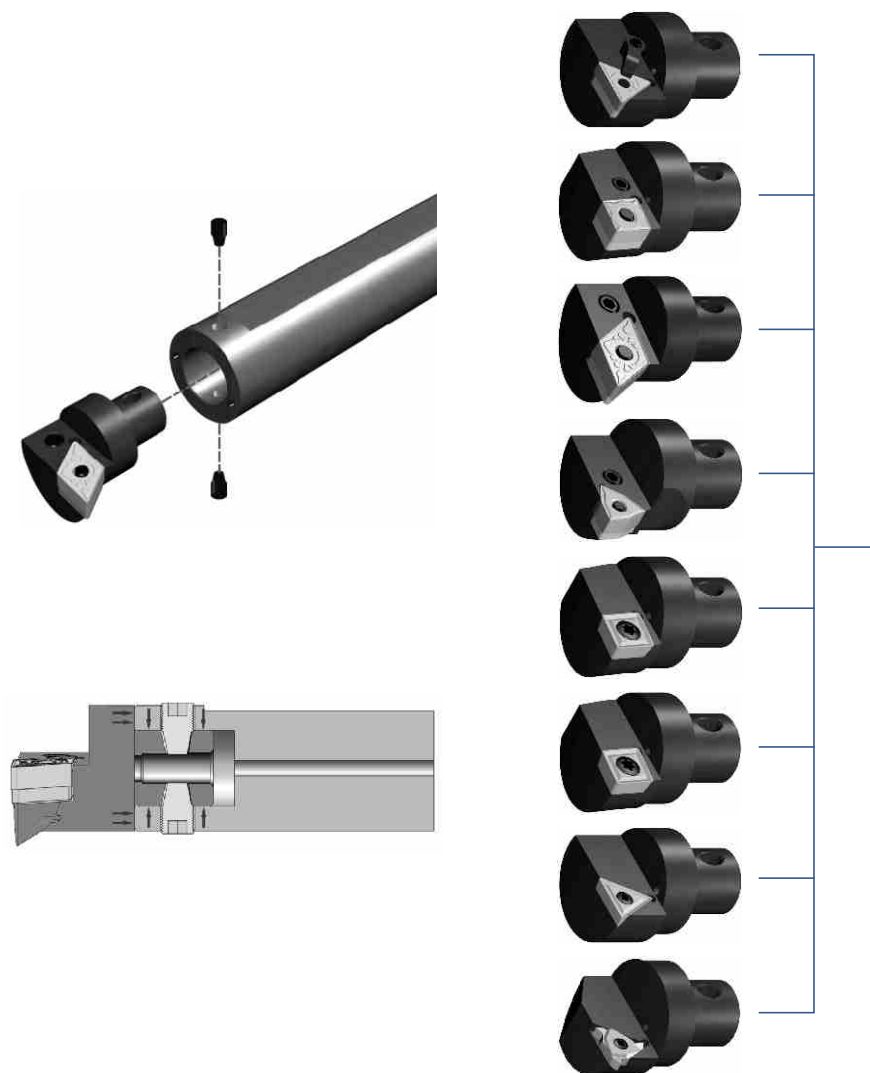



Characteristics:

Internal turning and profiling boring bar equipped with triangular negative double side insert with strong cutting edge. The center pin and top clamp ensure good rigidity and stability in roughing applications.

Applications:

Internal boring bar for general applications, roughing, semi-finishing and finishing.

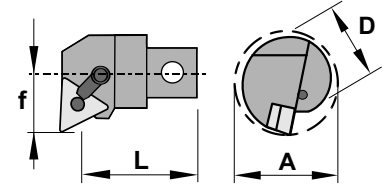

MTUN 93°



Characteristics:

Boring bars with internal coolant and anti-vibration shank.

		D	L	f	A	Insert size	
Ref.	A32X MTUN R/L 16	32	30	22	40	TNM.. 1604..	0,150
	A40X MTUN R/L 16	40	30	27	50	TNM.. 1604..	0,300
	A50X MTUN R/L 16	50	30	35	63	TNM.. 1604..	0,650
	A50X MTUN R/L 22	50	40	35	63	TNM.. 2204..	0,650
	A60X MTUN R/L 22	60	40	43	80	TNM.. 2204..	0,850

Ref.						
A32X MTUN R/L 16	2613	5003	3416	1086	1665	5002
A40X MTUN R/L 16	2613	5003	3416	1086	1665	5002
A50X MTUN R/L 16	2613	5003	3416	1086	1665	5002
A50X MTUN R/L 22	2613	5003	ITSN-433	1086	1666	5025
A60X MTUN R/L 22	2613	5003	ITSN-433	1086	1666	5025

Ref.	TNM..				Negative triangular inserts.		
					For more information see page: A.29		
	l	s	d	TNMG-CF	TNMG-CM	TNMG-CS	
TNM.. 1604..	16,50	4,76	9,52				
TNM.. 2204..	22,00	4,76	12,70				
TNMA	TNMG-CFC	TNMG-CFM	TNMG-CMC	TNMG-CMF	TNMG-CMR	TNMX	

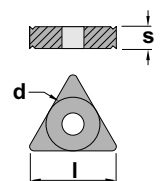

General turning
Aluminium wheel turning
Automatic lathes
Ceramic tools
Parting and grooving
Threading
Drills
Cartridges
Brazed tools
Tooling

Inserts

General turning



Characteristics:

Boring bar for internal turning applications equipped with rhombic negative inserts (angle 80°) and strong cutting edges.

The lever lock ensures good rigidity and chip flow in roughing applications.

Applications:

Internal boring bar for general applications, roughing, semi-finishing and finishing.

For low powered machines and small pieces choose boring bar Ref. SCLC (Page: C.30).

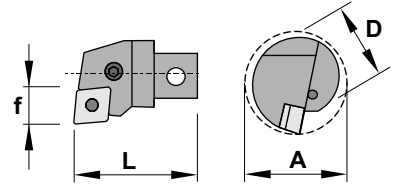

PCLN 95°



Characteristics:

Boring bars with internal coolant and anti-vibration shank.

Ref.		D	L	f	A	Insert size	Kg
A25X PCLN R/L 12		25	25	17	32	CN.. 1204..	0,050
A32X PCLN R/L 12		32	30	22	40	CN.. 1204..	0,150
A40X PCLN R/L 12		40	30	27	50	CN.. 1204..	0,300
A50X PCLN R/L 12		50	30	35	63	CN.. 1204..	0,600
A50X PCLN R/L 16		50	40	35	63	CN.. 1606..	0,600
A60X PCLN R/L 16		60	40	43	80	CN.. 1606..	0,800



Ref.		8212	1626	5025	-	-	-
A25X PCLN R/L 12		8212	1626	5025	-	-	-
A32X PCLN R/L 12		8312	1648	5003	3612	4112	0012
A40X PCLN R/L 12		8012	1608	5003	3612	4112	0012
A50X PCLN R/L 12		8012	1608	5003	3612	4112	0012
A50X PCLN R/L 16		8016	1618	5003	3616	4115	0015
A60X PCLN R/L 16		8016	1618	5003	3616	4115	0015

Ref.	CN..				Negative 80° rhombic inserts.			
	CN.. 1204..	l	s	d	CNMG-CF	CNMG-CM	CNMG-CR	CNMG-CS
	CN.. 1606..	12,90	4,76	12,70				
		16,10	6,35	15,88				
	CNGP	CNMA	CNMG-CFM	CNMG-CFC	CNMG-CMC	CNMG-CMF	CNMG-CMR	CNMM



Characteristics:

Boring bar for internal turning and profiling applications equipped with rhombic negative inserts (angle 55°) and strong cutting edges.

The lever lock ensures good rigidity and chip flow in roughing applications.

Applications:

Profiling boring bar for general applications, roughing, semi-finishing and finishing.

For low powered machines and small pieces choose boring bars Ref. SDUC (Page: C.34).

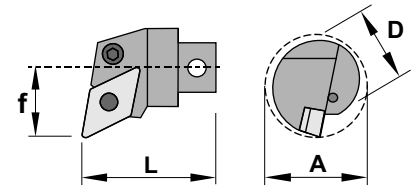

General turning

Aluminium wheel turning

Automatic lathes

Ceramic tools

Parting and grooving

Threading

Drills

Cartridges

Brazed tools

Tooling

PDUN 93°



Characteristics:

Boring bars with internal coolant and anti-vibration shank.

Ref.		D	L	f	A	Insert size	kg
A32X PDUN R/L 15		32	30	22	40	DN.. 1506..	0,150
A40X PDUN R/L 15		40	30	27	50	DN.. 1506..	0,300
A50X PDUN R/L 15		50	40	35	63	DN.. 1506..	0,600
A60X PDUN R/L 15		60	40	43	80	DN.. 1506..	0,800



Ref.	A32X PDUN R/L 15	A40X PDUN R/L 15	A50X PDUN R/L 15	A60X PDUN R/L 15	8415	1648	1638	1638	1638	5003	3715	4112	4112	4112	4112	0012	0012	0012	0012	3725	3725	3725	3725	
A32X PDUN R/L 15	8415	1648	1638	1638	5003	3715	4112	0012	3725															
A40X PDUN R/L 15	8415	1638	5003	3715	4112	0012	3725																	
A50X PDUN R/L 15	8415	1638	5003	3715	4112	0012	3725																	
A60X PDUN R/L 15	8415	1638	5003	3715	4112	0012	3725																	

For DNM.. 1504.. inserts

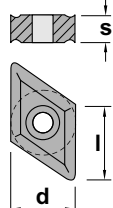

DN..

l

s

d

Negative 55° rhombic inserts.

For more information see page: A.22

Ref.	DN.. 1504..	DN.. 1506..	15,50	4,76	12,70	15,50	6,35	12,70	DNMG-CF	DNMG-CM	DNMG-CS					
	DNGP	DNMA	DNMG-CFC	DNMG-CFM	DNMG-CMC	DNMG-CMF	DNMG-CMR	DNMX								

Inserts

General turning



Characteristics:

Boring bar for internal turning applications equipped with trigon negative inserts (angle 80°) and strong cutting edges.

The lever lock ensures good rigidity and chip flow in roughing applications.

Applications:

Internal boring bar for general applications, roughing, semi-finishing and finishing.

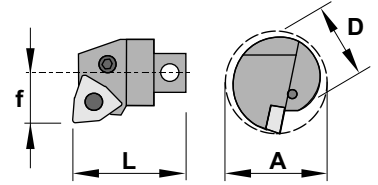

PWLN 95°



Characteristics:

Boring bars with internal coolant and anti-vibration shank.

Ref.		D	L	f	A	Insert size	Kg
A32X PWLN R/L 08		32	30	22	40	WNM.. 0804..	0,150
A40X PWLN R/L 08		40	30	27	50	WNM.. 0804..	0,300
A50X PWLN R/L 08		50	40	35	63	WNM.. 0804..	0,600
A60X PWLN R/L 08		60	40	43	80	WNM.. 0804..	0,800



Ref.	A32X PWLN R/L 08	A40X PWLN R/L 08	A50X PWLN R/L 08	A60X PWLN R/L 08	8312	1648	5003	3008	4112	0012
A32X PWLN R/L 08					8312	1648	5003	3008	4112	0012
A40X PWLN R/L 08					8012	1608	5003	3008	4112	0012
A50X PWLN R/L 08					8012	1608	5003	3008	4112	0012
A60X PWLN R/L 08					8012	1608	5003	3008	4112	0012

	WNM..				Negative 80° trigon inserts.		
	Ref.	l	s	d	For more information see page: A.34		
	WNM.. 0804..	8,14	4,76	12,70	WNMG-CF	WNMG-CM	WNMG-CS
	WNMA	WNMG-CFM	WNMG-CMC	WNMG-CMF	WNMG-CMR		



Characteristics:

Multipurpose boring bar equipped with rhombic positive insert (angle 80°).
The center screw ensures good rigidity and chip flow.

Applications:

Internal boring bar for general applications, roughing, semi-finishing and finishing.

Negative inserts boring bars Ref. PCLN (Page: C.22).

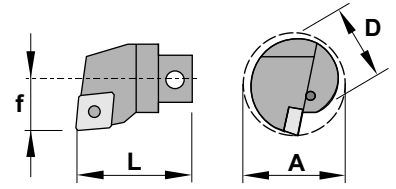





SCLC 95°







Characteristics:

Boring bars with internal coolant and anti-vibration shank.

Ref.		D	L	f	A	Insert size	kg
A20X SCLC R/L 09		20	25	13	25	CC.. 09T3..	0,030
A25X SCLC R/L 09		25	25	17	32	CC.. 09T3..	0,070
A32X SCLC R/L 12		32	30	22	40	CC.. 1204..	0,150
A40X SCLC R/L 12		40	30	27	50	CC.. 1204..	0,250
A50X SCLC R/L 12		50	40	35	63	CC.. 1204..	0,650
A60X SCLC R/L 12		60	40	43	80	CC.. 1204..	0,850

Ref.					
A20X SCLC R/L 09		1440	5515	-	-
A25X SCLC R/L 09		1440	5515	-	-
A32X SCLC R/L 12		1540	5517	3614	1760
A40X SCLC R/L 12		1540	5517	3614	1760
A50X SCLC R/L 12		1540	5517	3614	1760
A60X SCLC R/L 12		1540	5517	3614	1760

Ref.	CC..	l	s	d	Positive 7° clearance - 80° Rhombic inserts.
	CC.. 09T3..	9,65	3,97	9,52	
CC.. 1204..	12,90	4,76	12,70		

CCGT-AL	CCGT-AP	CCMT-03	CCMW
			

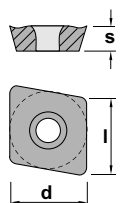

For more information see page: A.18

Inserts

General turning



Characteristics:

Multipurpose profiling boring bar equipped with rhombic positive insert (angle 55°). The center screw ensures good rigidity and chip flow.

Applications:

Profiling boring bar for general applications, roughing, semi-finishing and finishing.

Negative inserts boring bars Ref. PDUN (Page: C.23).

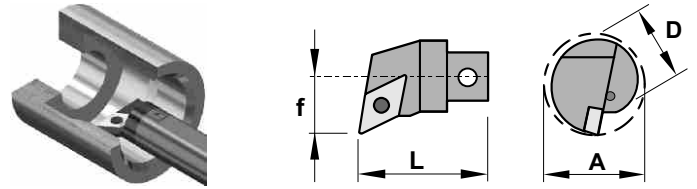

SDUC 93°



Characteristics:

Boring bars with internal coolant and anti-vibration shank.

Ref.		D	L	f	A	Insert size	
A20X SDUC R/L 11		20	25	13	25	DC.. 11T3..	0,030
A25X SDUC R/L 11		25	25	17	32	DC.. 11T3..	0,070
A32X SDUC R/L 11		32	30	22	40	DC.. 11T3..	0,150
A40X SDUC R/L 11		40	30	27	50	DC.. 11T3..	0,250
A50X SDUC R/L 11		50	40	35	63	DC.. 11T3..	0,650
A60X SDUC R/L 11		60	40	43	80	DC.. 11T3..	0,850

Ref.				
A20X SDUC R/L 11	1240	5515	-	-
A25X SDUC R/L 11	1240	5515	-	-
A32X SDUC R/L 11	1335	5516	3714	1750
A40X SDUC R/L 11	1335	5516	3714	1750
A50X SDUC R/L 11	1335	5516	3714	1750
A60X SDUC R/L 11	1335	5516	3714	1750

	DC..				Positive 7° clearance - 55° Rhombic inserts.
	Ref.	l	s	d	
	DC.. 11T3..	11,60	3,97	9,52	
	DCGT-AL	DCGT-AP	DCMT-03	DCMW	

For more information see page: A.21



Characteristics:

Multipurpose boring bar equipped with triangular positive insert.
The center screw ensures good rigidity and chip flow.

Applications:

Internal boring bar for general applications, roughing, semi-finishing and finishing.

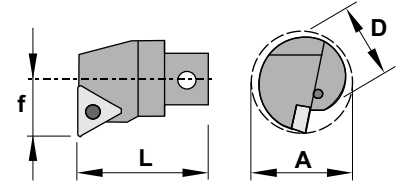

STFC 90°



Characteristics:

Boring bars with internal coolant and anti-vibration shank.

Ref.		D	L	f	A	Insert size	
A20X STFC R/L 16		20	25	13	25	TC.. 16T3..	0,030
A25X STFC R/L 16		25	25	17	32	TC.. 16T3..	0,070
A32X STFC R/L 16		32	30	22	40	TC.. 16T3..	0,150
A40X STFC R/L 16		40	30	27	50	TC.. 16T3..	0,250
A50X STFC R/L 16		50	40	35	63	TC.. 16T3..	0,650
A60X STFC R/L 16		60	40	43	80	TC.. 16T3..	0,850

Ref.				
A20X STFC R/L 16	1240	5515	-	-
A25X STFC R/L 16	1240	5515	-	-
A32X STFC R/L 16	1335	5516	3414	1750
A40X STFC R/L 16	1335	5516	3414	1750
A50X STFC R/L 16	1335	5516	3414	1750
A60X STFC R/L 16	1335	5516	3414	1750

	TC..				Positive 7° clearance - Triangular inserts
	Ref.	TC.. 16T3..	l	s	
			16,50	3,97	9,52
	TCGT-AL	TCMT-03	TCMW		

For more information see page: A.28

Inserts

General turning



Characteristics:

Threading boring bar equipped with triangular negative insert. The center screw ensures good rigidity and chip flow.

Applications:

Internal threading boring bar.

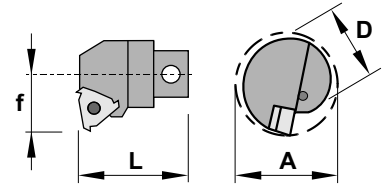

SXFN 90°



Characteristics:

Boring bars with internal coolant and anti-vibration shank.

Ref.		D	L	f	A	Insert size	Kg
A20X SXFN R/L 16	A20X SXFN R/L 16	20	25	13,40	25	16 NR/L..	0,030
	A25X SXFN R/L 16	25	20	16,30	32	16 NR/L..	0,070
	A32X SXFN R/L 16	32	32	19,60	40	16 NR/L..	0,150
A25X SXFN R/L 22	A25X SXFN R/L 22	25	25	17,20	32	22 NR/L..	0,070
	A32X SXFN R/L 22	32	32	21,50	40	22 NR/L..	0,150
	A40X SXFN R/L 22	40	32	25,80	50	22 NR/L..	0,250
	A50X SXFN R/L 22	50	40	31,40	63	22 NR/L..	0,650
	A60X SXFN R/L 22	60	40	36,40	80	22 NR/L..	0,850

Ref.						
A20X SXFN R/L 16	A20X SXFN R/L 16	SA3T	5510	YE3	YI3	SY3
	A25X SXFN R/L 16	SA3	5510	YE3	YI3	SY3
	A32X SXFN R/L 16	SA3	5510	YE3	YI3	SY3
A25X SXFN R/L 22	A25X SXFN R/L 22	SA4	5520	-	-	-
	A32X SXFN R/L 22	SA4	5520	YE4	YI4	SY4
	A40X SXFN R/L 22	SA4	5520	YE4	YI4	SY4
	A50X SXFN R/L 22	SA4	5520	YE4	YI4	SY4
	A60X SXFN R/L 22	SA4	5520	YE4	YI4	SY4

	N R/L				Negative triangular inserts for internal threading.
	Ref.	l	s	d	
	16 NR/L..	16,50	3,18	9,52	
22 NR/L..	22,00	4,76	12,70		
	N R/L	N R/L TD			

For more information see page: H.05



General turning

Aluminum
wheel turning

Automatic lathes

Ceramic tools

Parting and
grooving

Threading

Drills

Cartridges

Brazed tools

Tooling

Inserts

General turning



Characteristics:

Multipurpose boring bar equipped with rhombic positive insert (angle 80°).
 The center screw ensures good rigidity and chip flow.

Applications:

Internal boring bar for general applications, roughing, semi-finishing and finishing.

Negative inserts boring bars Ref. PCLN (Page: C.22).

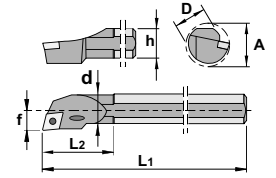

SET SCLC 95°



Characteristics:
 Boring bars with internal coolant.

Ref.	D	d	L1	L2	f	A	h	Insert size	
A0608H SCLC R/L 06	8	6	100	25	4	10	7	CC.. 0602..	0,400
A0810J SCLC R/L 06	10	8	110	32	6	12	9	CC.. 0602..	
A1012K SCLC R/L 06	12	10	125	38	7	14	11	CC.. 0602..	
A1216M SCLC R/L 06	16	12	150	50	9	18	15	CC.. 0602..	



Ref.	A0608H SCLC R/L 06	1425	5507
	A0810J SCLC R/L 06	1425	5507
	A1012K SCLC R/L 06	1225	5507
	A1216M SCLC R/L 06	1225	5507

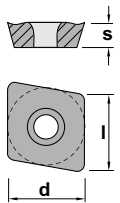

CC..

l

s

d

Positive 7° clearance - 80° rhombic inserts.

Ref.	CC.. 0602..	6,45	2,38	6,35
------	-------------	------	------	------

For more information see page: A.18

CCGT-AL

CCGT-AP

CCMT-03

CCMW





Characteristics:

Multipurpose profiling boring bar equipped with rhombic positive insert (angle 55°). The center screw ensures good rigidity and chip flow.

Applications:

Profiling boring bar for general applications, roughing, semi-finishing and finishing.

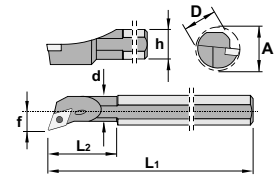

SET SDQC 107°30'



Characteristics:
Boring bars with internal coolant.

Ref.	D	d	L1	L2	f	A	h	Insert size	
A0810J SDQC R/L 07	10	8	110	32	7	12,5	9	DC.. 0702..	0,350
A1012K SDQC R/L 07	12	10	125	38	9	15,5	11	DC.. 0702..	
A1216M SDQC R/L 07	16	12	150	50	11	19,5	15	DC.. 0702..	

General turning

Aluminum wheel turning

Automatic lathes

Ceramic tools

Parting and grooving

Threading

Drills

Cartridges

Brazed tools

Tooling

Ref.		
A0810J SDQC R/L 07	1425	5507
A1012K SDQC R/L 07	1225	5507
A1216M SDQC R/L 07	1225	5507

	DC..				Positive 7° clearance - 55° Rhombic inserts.
	Ref.	l	s	d	
	DC.. 0702..	9,52	2,38	6,35	
	DCGT-AL	DCGT-AP	DCMT-03	DCMW	

For more information see page: A.21

Inserts

General turning



Characteristics:

Multipurpose profiling boring bar equipped with rhombic positive insert (angle 55°). The center screw ensures good rigidity and chip flow.

Applications:

Profiling boring bar for general applications, roughing, semi-finishing and finishing.

Negative inserts boring bars Ref. PDUN (Page: C.23).

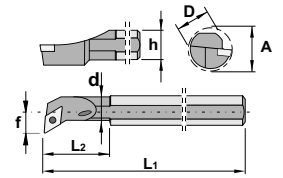

SET SDUC 93°



Characteristics:

Boring bars with internal coolant.

Ref.	D	d	L1	L2	f	A	h	Insert size	Kg
A0810J SDUC R/L 07	10	8	110	32	7	12,5	9	DC.. 0702..	0,350
A1012K SDUC R/L 07	12	10	125	38	9	15,5	11	DC.. 0702..	
A1216M SDUC R/L 07	16	12	150	50	11	19,5	15	DC.. 0702..	



Ref.	A0810J SDUC R/L 07	1425	5507
	A1012K SDUC R/L 07	1225	5507
	A1216M SDUC R/L 07	1225	5507

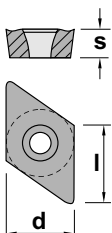

DC..

l

s

d

Positive 7° clearance - 55° rhombic inserts.

Ref.	DC.. 0702..	9,52	2,38	6,35
------	-------------	------	------	------

For more information see page: A.21

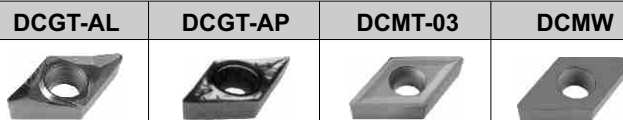



Characteristics:

Multipurpose boring bar equipped with triangular positive insert.
The center screw ensures good rigidity and chip flow.

Applications:

Internal boring bar for general applications, roughing, semi-finishing and finishing.

Negative inserts boring bars Ref. PTFN (Page: C.27).

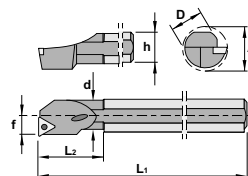

SET STFC 90°



Characteristics:

Boring bars with internal coolant.

Ref.		D	d	L1	L2	f	A	h	Insert size	Kg
A0810J STFC R/L 11		10	8	110	32	7	12,5	9	TC.. 1102..	0,350
A1012K STFC R/L 11		12	10	125	38	9	15,5	11	TC.. 1102..	
A1216M STFC R/L 11		16	12	150	50	11	19,5	15	TC.. 1102..	



Ref.			
A0810J STFC R/L 11		1425	5507
A1012K STFC R/L 11		1225	5507
A1216M STFC R/L 11		1225	5507

Ref.	TC..			Positive 7° clearance - Triangular inserts
	l	s	d	
TC.. 1102..	11,00	2,38	6,35	For more information see page: A.28
TCGT-AL	TCMT-03	TCMW		

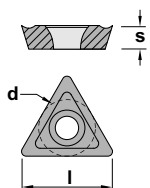

General turning

Aluminium wheel turning

Automatic lathes

Ceramic tools

Parting and grooving

Threading

Drills

Cartridges

Brazed tools

Tooling

Nominal cutting speed and feed values for boring bars

Material	P	HB	Condition	Cutting speed m/min.					Specific cutting force K _{0,4}	
				PM 25	PM 40	NC 25	TIN 16	TIN 22		TIN 32
				0.3-0.6-1.2		0.1 - 0.3		0.1-0.4-0.8		0.2-0.5-1.2
Unalloyed steel	125	C=0.15%	150 115 80		350 280	480 345 250	440 300 205	330 230 110	1900	
	150	C=0.35%	145 105 70		270 230	440 315 230	400 275 190	300 210 150	2100	
	200	C=0.60%	115 90 65		240 190	385 275 200	350 240 165	260 185 130	2250	
Low alloyed steel	180	Annealed	90 70 45		300 260	380 265 195	320 220 170	200 140 100	2100	
	275	Hardened	65 45 30		220 140	260 180 130	215 150 115	140 100 70	2600	
	300	Hardened	60 40 25		230 180	240 165 120	200 135 105	125 90 60	2700	
	350	Hardened	50 35 20		220 140	210 145 105	170 120 90	110 75 55	2850	
High alloyed steel	200	Annealed	80 60 45		200 160	350 230 170	280 185 135	175 115 80	2600	
	325	Hardened	40 25 20		200 160	170 110	120 80 60	85 55 40	3900	
Stainless steel	200	Martensitic/Ferritic	110 95 75		270 130	295 240 190	275 210 165	225 180 145	2300	
Steel castings	180	Unalloyed	60 50 35		300 260	260 185 145	230 160 120	135 105 75	2000	
	200	Low alloyed	50 45 30		230 180	230 160 120	190 125 85	120 90 60	2500	
	225	High alloyed	40 30 20		220 140	190 130 95	170 115 80	95 70 55	2700	

Material	M	HB	Condition	Cutting speed m/min.						Specific cutting force K _{0,4}		
				PM 25	PM 40	NC 25	TIN 16	TIN 17	TIN 22		TIN 32	TIN 35
				0.1-0.3		0.1-0.3		0.1-0.4-0.8			0.1-0.3	
Stainless steel annealed	180	Austenitic Ni > 8%, Cr 12-25% Austenitic/Ferritic Austenitic/Ferritic, Low S	205 170		240 200	180 150 120	600 100		190 160 130	190 160 130	2450	
					160 130	180 150 120	400 100		190 160 100	190 160 130		
					160 130	180 150 120	400 100		140 110	160 130 100		
Heat resistant alloys	200	Annealed					50 20		40 20	40 20	3000	
	280	Aged					50 20		35 15	35 15	3050	
	250	Annealed					40 15		25 6	25 8	3500	
	350	Aged					35 20		15 4	15 4	4150	
	320	Cast					25 10		15 4	15 4	4150	
Titanium alloys	400	Ti					140 80			80 130	1530	
	950	Cast a, almost a and a+b					45 25			15 35	1675	
	1050	Aged cast a+b					45 25			15 35	1690	

Material	K	HB	Condition	Cutting speed m/min.					Specific cutting force K _{0,4}	
				KM 15	TIN 17	NC 25	TIN 16	TIN 22		ZR 10
				0.2-0.5-1.0		0.2-0.5-1.0		0.2-0.5		0.2-0.5-1.0
Hardened steel	350	Hardened steel	27 16 10	180 150 110		175 145 100			4500	
	250	Manganese steel 12%	65 40 16	120 90 60		120 85 50			3600	
Malleable cast iron	130	Ferritic	105 75 45	250 180 100		225 150 90			1100	
	230	Pearlitic	80 60 30	160 100 60		155 95 55			1100	
Cast iron	180	Low tensile strength	135 95 60	180 120 80	300 200	165 110 70			1100	
	260	High tensile strength	95 65 40	140 105 60	250 180	120 90 55			1500	
Nodular SG iron	160	Ferritic	115 80 45	220 180 100	250 180				1100	
	250	Pearlitic	80 50 30	150 100 50	180 120				1800	
Chilled cast iron	400		17 11	17 11					3000	
Aluminium alloys	60	Non heat treatable	1750 1280 800	1750 1280 800				1750 1280 800	500	
	100	Heat treatable	510 370 250	510 370 250				510 370 250	800	
Aluminium alloys (Cast)	75	Non heat treatable	460 285 175	460 285 175				460 285 175	750	
	90	Heat treatable	300 180 110	300 180 110				300 180 110	900	
Bronze -Brass alloys	110	Lead alloys, Pb>1%	610 430 295	610 430 295				610 430 295	700	
	90	Brass and bronze	310 250 195	310 250 195				310 250 195	750	
	100	Inc. electrolytic copper	225 160 115	225 160 115				225 160 115	1750	
Other materials		Hard plastics	380 240	380 240				380 240		
		Fibre	190 120	190 120				190 120		
		Hard rubber	225 160	225 160				225 160		



Very often some special tools are required to achieve different kinds of application, either to reduce the time of machining or because there is no standard tool which can accomplish a specific machining operation. Eines CANELA gives to his customers the possibility of manufacturing this kind of tooling, starting from a drawing or making a study about the piece which must be machined. The wide range of possibilities offered by the manufacture of special tooling helps to solve all kind of machining problems from the small to the aerospace industry.

General turning

Aluminium
wheel turning

Automatic lathes

Ceramic tools

Parting and
grooving

Threading

Drills

Cartridges

Brazed tools

Tooling