

Inserts

General turning

Aluminium
wheel turning

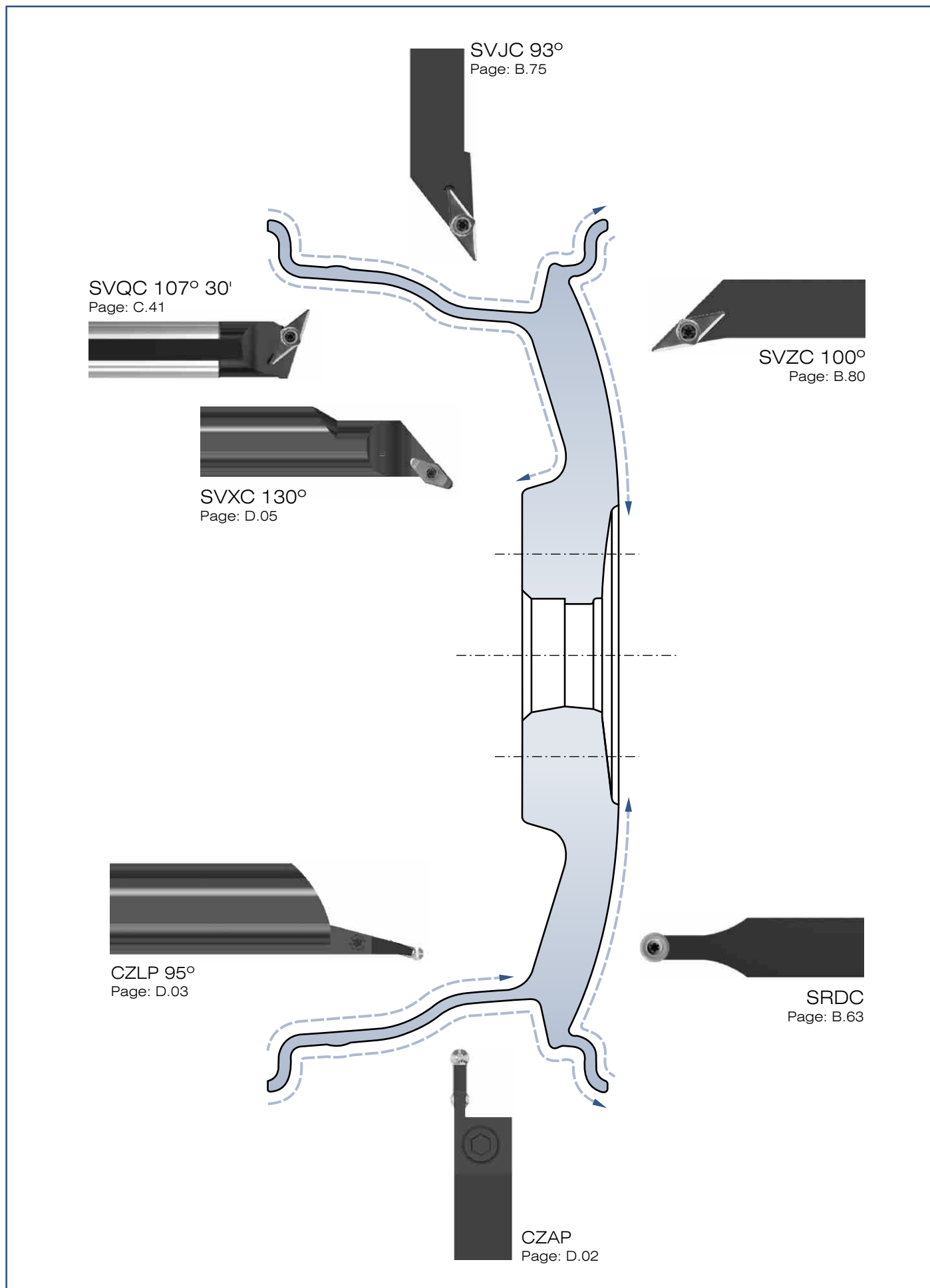



Aluminium wheel turning
Automatic lathes
Ceramic tools
Parting and grooving
Threading
Drills
Cartridges
Brazed tools
Tooling

Inserts

General turning

Aluminium wheel turning

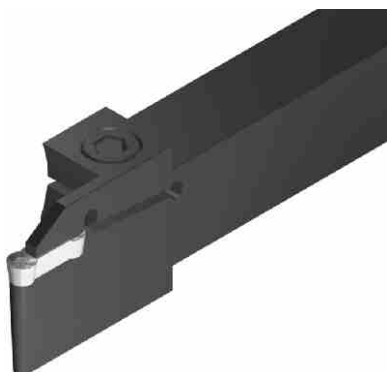

Characteristics:

Double sided inserts with radius from 3 to 4 mm.

The "V" positioning system of the pocket and the clamp integrated to the tool ensure maximum security and repetitivity on the dimensions when the insert is changed.

Applications:

External wheel turning.

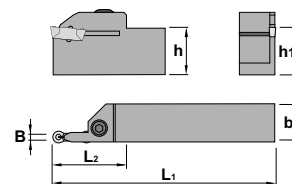

CZAP

Ref.		h=h1	b	L1	L2	B	Insert size	
CZAPR2525M30		25	25	150	24	6	GXGP-253.0	0,550
CZAPR2525M40		25	25	150	24	6	GXGP-254.0	0,550
CZAPR3232P40		32	32	170	24	8	GXGP-254.0	1,100



Ref.		1096	5005
CZAPR2525M30		1096	5005
CZAPR2525M40		1096	5005
CZAPR3232P40		1096	5005

GXGP-AL

l

s

Double-ended insert

Ref.		25,37	6,0
GXGP-253.0-AL		25,37	8,0
GXGP-254.0-AL			

For more information see page: A.25

GXGP-AL

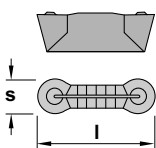



Characteristics:

Double sided inserts with radius from 3 to 4 mm.

The "V" positioning system of the pocket and the clamp integrated to the tool ensure maximum security and repetitivity on the dimensions when the insert is changed.

Applications:

Internal wheel turning.

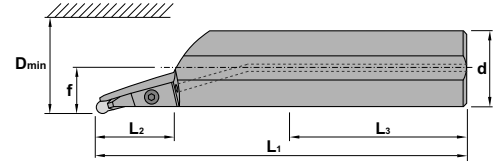

CZLP 95°

Ref.		d	h	L1	L2	L3	f	Dmin	Insert size	kg
A40T-CZLPR-30		40	37	300	40	109	28	200	GXGP-253.0	2,650
A40T-CZLPR-40		40	37	300	80	109	28	200	GXGP-254.0	2,650

Ref.	A40T-CZLPR-30	A40T-CZLPR-40		
A40T-CZLPR-30			1096	5005
A40T-CZLPR-40			1096	5005

Enquiry form

If you need any modification from the standard, please submit this enquiry form

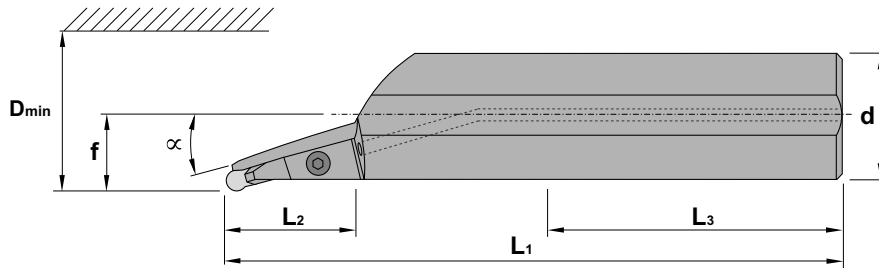

Dimensions	d	h	L1	L2	L3	f	Dmin	α

Comments:

.....

.....

.....

Ref.	GXGP-AL		I		s		Double-ended insert																
	GXGP-253.0-AL		25,37		6,0			For more information see page: A.25															
GXGP-254.0-AL		25,37		8,0																			
<table border="1"> <thead> <tr> <th>GXGP-AL</th> <th></th> <th></th> <th></th> <th></th> <th></th> <th></th> <th></th> </tr> </thead> <tbody> <tr> <td> </td> <td> </td> <td> </td> <td> </td> <td> </td> <td> </td> <td> </td> <td> </td> </tr> </tbody> </table>								GXGP-AL															
GXGP-AL																							

Aluminium wheel turning

Automatic lathes

Ceramic tools

Parting and grooving

Threading

Drills

Cartridges

Brazed tools

Tooling

Inserts

General turning

Aluminium wheel turning



Characteristics:

Double sided inserts with radius from 3 to 4 mm.

The "V" positioning system of the pocket and the clamp integrated to the tool ensure maximum security and repetitivity on the dimensions when the insert is changed.

Applications:

Internal wheel turning.

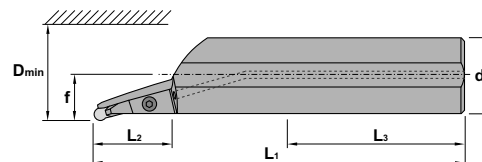

CZXP 105°

Ref.	d	h	L1	L2	L3	f	Dmin	Insert size	
A40T-CZXPR-40	40	37	300	80	80	28	55	GXGP-254.0	2,650

Ref.	A40T-CZXPR-40		1096		5005
------	---------------	--	------	--	------

Enquiry form

If you need any modification from the standard, please submit this enquiry form

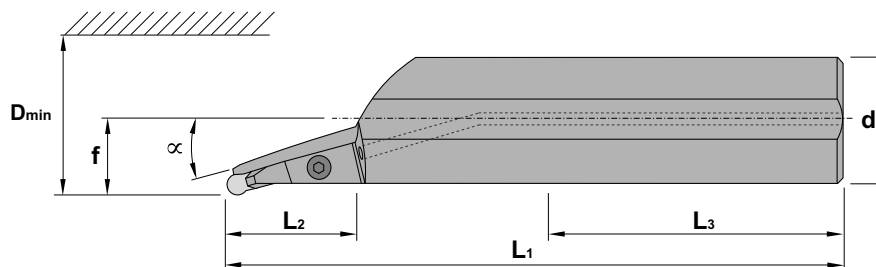

Dimensions	d	h	L1	L2	L3	f	Dmin	α

Comments:

.....

.....

.....

	GXGP-AL		l	s	Double-ended insert
	Ref.	GXGP-254.0-AL	25,37	8,0	
	GXGP-AL				

For more information see page: A.25



Characteristics:

Multipurpose profiling boring bar equipped with rhombic positive insert (angle 35°).
The center screw ensures good rigidity and chip flow.

Applications:

Internal wheel turning.

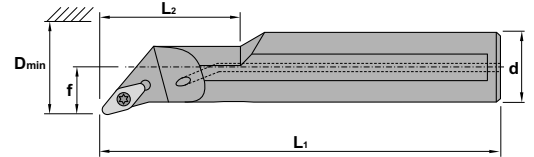

SVXC 130°									
Ref.	A40S-SVXCR/L-22	d	h	L1	L2	f	Dmin	Insert size	
		40	37	250	80	27	45	VC.. 2205..	2,200

Ref.	A40S-SVXCR/L-22		1250		5520
------	-----------------	--	------	--	------

Enquiry form

If you need any modification from the standard, please submit this enquiry form

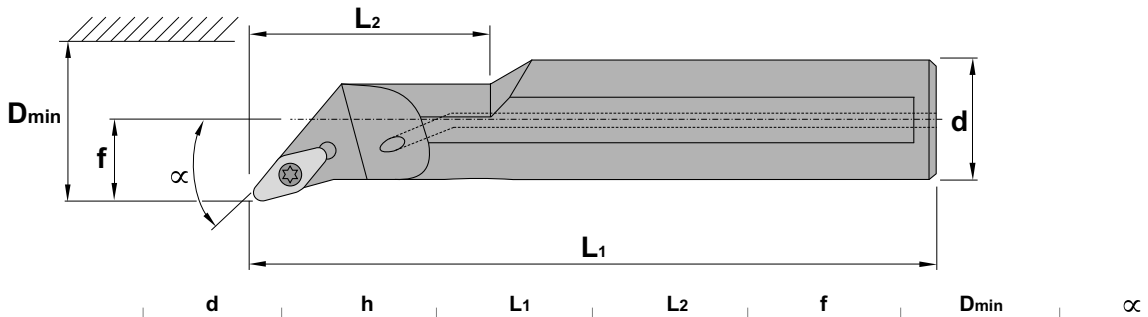

Dimensions	d	h	L1	L2	f	Dmin	α
------------	---	---	----	----	---	------	----------

Comments:

.....

.....

		VCGT			Positive 7° clearance - 35° rhombic inserts
Ref.	VCGT 2205..	l	s	d	
		22,10	5,56	12,70	For more information see page: A.32
	VCGT-AL				
	VCGT-AP				

- Aluminium wheel turning
- Automatic lathes
- Ceramic tools
- Parting and grooving
- Threading
- Drills
- Cartridges
- Brazed tools
- Tooling

Inserts

General turning

Aluminium wheel turning

Characteristics:

Multipurpose profiling boring bar equipped with rhombic positive insert (angle 35°). The center screw ensures good rigidity and chip flow.

Applications:

Internal wheel turning.

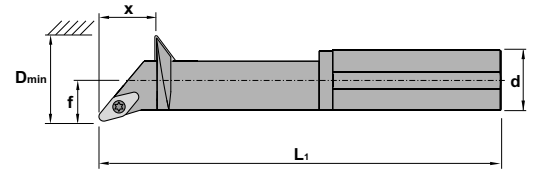

Enquiry form

If you need any modification from the standard, please submit this enquiry form

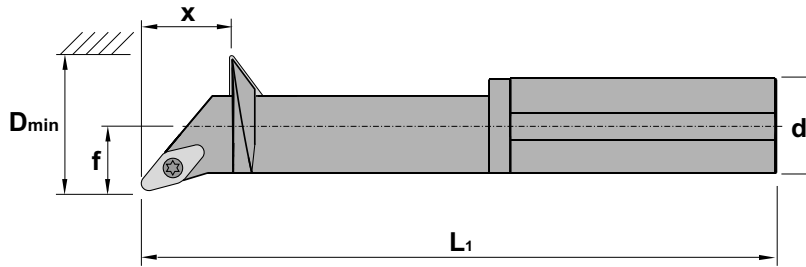

d h L₁ x f D_{min} α

Dimensions

Comments:

.....

.....

.....

	VCGT				Positive 7° clearance - 35° rhombic inserts				
	Ref.	VCGT 2205..	l	22,10		s	5,56	d	12,70
	For more information see page: A.32								
	VCGT-AL	VCGT-AP							



Very often some special tools are required to achieve different kinds of application, either to reduce the time of machining or because there is no standard tool which can accomplish a specific machining operation. Eines CANELA gives to his customers the possibility of manufacturing this kind of tooling, starting from a drawing or making a study about the piece which must be machined. The wide range of possibilities offered by the manufacture of special tooling helps to solve all kind of machining problems from the small to the aerospace industry.

Aluminium
wheel turning

Automatic lathes

Ceramic tools

Parting and
grooving

Threading

Drills

Cartridges

Brazed tools

Tooling